

FETCO® User's Guide, Operator Instructions and Access

FETCO Models:



CBS-2151XTS



CBS-2152XTS



CBS-2152-2XTS

6-liter/1 ½ -gallon

7.3-liter-2gallon

hot beverage brewers

Commercial Hot Beverage Equipment

Table of Contents

Contact Information.....	2	Operator Training	14
Description & Features	2	Safety Notes	13
Factory settings.....	2	Error Codes	13
Accessing equipment and control screens	3	Service Guide to a Successful Installation	15
Layout of the brewer	3	Installation Directions	16
Accessing batch and programming menu screens.....	3	CBS-2150XTS Dimensions & Utility Connections.....	18
Operating Instructions.....	4	Final Setup for Startup.....	22
Programming- operator access programming	6	Parts and Wiring Diagrams	24
Menu Features: Batch Parameters.....	7		
How to calibrate the flow rate.....	11		



NOTICE TO INSTALLER: Please leave this book with the machine.

Contact Information

FETCO®
Food Equipment Technologies Company
600 Rose Road
Lake Zurich • IL • 60047-0429 • USA
Phone: (847) 719-3000
Toll Free: (800)FETCO.99 or (800) 338-2699
Internet: www.fetco.com

Technical Support
techsupport@fetco.com

General Inquiries: info@fetco.com
Sales (North Americas): sales@fetco.com
Sales (International): international@fetco.com

Description & Features

CBS-2150XTS Series coffee brewers feature universal spray over technology from the Cascading Spray Dome™.

The following variables are programmed for each batch size:

- ❖ Brew volume
- ❖ Brew time
- ❖ Adjustable number of pulses
- ❖ Drip delay (The time between the end of the brew cycle and end of the brewing cycle...to empty the brewbasket)
- ❖ Prewet percent (Percentage of the brew volume)
- ❖ Prewet delay (The time between prewetting and the brew cycle)
- ❖ Bypass-indefinitely variable for strength adjustment

Operating Principles

Using these variables, the software calculates how much water to use for prewetting and brewing. The total brew time digitally divides into several cycles. Within these cycles, the software calculates how long to spray water over the coffee grounds, and how long to pause before the next cycle begins. If desired, pulse count and length, brew-volume may be adjusted without changing brew time and brew-time may be adjusted without changing volume brewed.

Factory settings

The following are the factory set defaults—all variables in the brew menu are adjustable:

Brew Volume and coffee filter size:

CBS-2150 single and Twin: 1.5 gallon/6 liters per brew Coffee Filters: 15" X 5 ½"

CBS-2152-2 Gallon Twin EXPORT ONLY: 2 gallon/7.6 liters per brew Coffee Filters: 15" X 5 ½"

Brew Time, all models: Factory set at 5.5 minutes=[4 minute brew time + 1.5 minute drip delay]

Temperature Control: Water temperature is factory set at —93°C/200°F

Features

- ❖ Touchscreen Operation [X**T**S: EX**T**ractor Touch **S**creen]
- ❖ Cascading Spray Dome-No clog sprayhead
- ❖ Brew mechanism is digitally adjustable
- ❖ Intuitive Control Settings for Batch sizing
- ❖ Indefinitely variable bypass for strength adjustment
- ❖ Four fully programmable batch sizes per side
- ❖ User programs save-to and load-from SD cards
- ❖ Recipe copy to SD card
- ❖ Customizable batch name
- ❖ Screen logo customizable by user from SD card
- ❖ SD card firmware program and upgrade installation
- ❖ Universal wiring – single or 3 phase
- ❖ Brew water low temperature lockout
- ❖ ECO mode for tank heater energy savings
- ❖ Dispenser locator under brew basket
- ❖ Magnetic flux brew basket sensor
- ❖ Brewbasket locks (configurable)
- ❖ Totalizing counters for brewer functions
- ❖ Optional gourmet stainless steel brewbasket
- ❖ Demonstration Mode for review & training
- ❖ Heavier gauge stainless steel cabinet
- ❖ Configurable for FLOWJET® pump module
- ❖ SD card Backup for menu items

Accessing equipment and control screens

Layout of the brewer

- Touch-screen for brewer operation
- Brew basket sensor (internal)
- SD card interface port (Load & Save)
- Hot Water Faucet
- Airpot or Dispenser Locator (Two for dual side)
- Main power switch
- Slide out back panel for service access

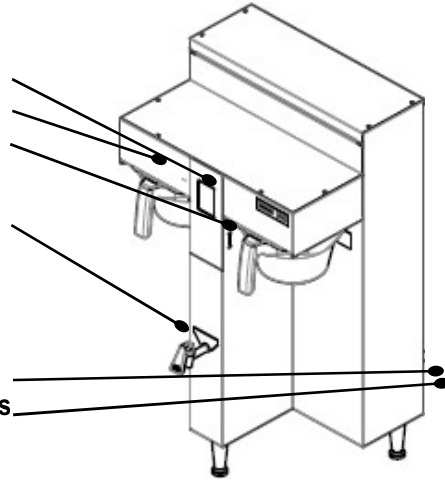

Accessing batch and programming menu screens



CBS-2100 home screen shown

← CBS_2100XTS brewer HOME SCREEN:
Tap to enter batch selection screen.

←Tap left or right side batches→
...AND...

Select and hold down a batch selector pennant to begin brew.

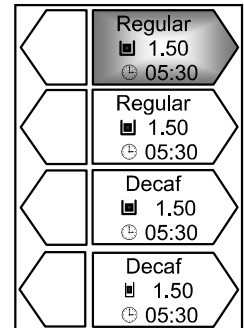

Batch selection screen

Accessing the menu screens for programming



CBS-2100 home screen shown

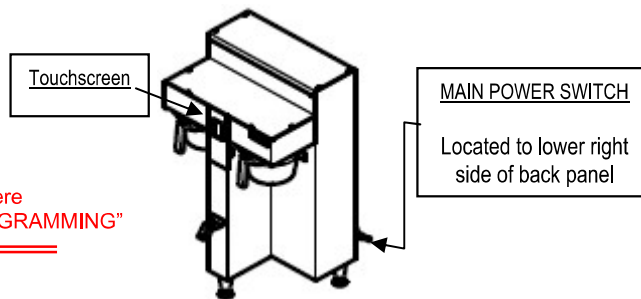

Touch/Hold here to enter "PROGRAMMING"

MAIN POWER SWITCH

Located to lower right side of back panel



CBS-2100 home screen shown
Shown in optional "ECO" Mode



CBS-2100 home screen shown

- From power "OFF"
- Touch screen will briefly illuminate
- Turn main power switch to "ON" (Switch located lower right side of back panel)
- When Complete: the HOME SCREEN will display
- Immediately touch and hold finger to enter programming
- Lower portion of the screen will highlight as shown
- In 5-8 seconds "PROGRAMMING" screen will appear→

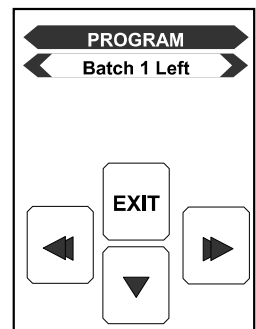

→Quick brewer setup

NOTES

Install plumbing and electrical utilities	-See Installation Section in this guide
Turn rear power switch “ON”	-Located on back, lower right side
<i>Brewer hot water tank will fill in 4-8 minutes</i>	-Ready screen will display “▪FILLING”
Heater(s) activate when tank is full	-Ready screen will display “▪HEATING”
<i>Initial heating will be 15-30 minutes</i>	-Place dispenser under brewbasket(s) to collect any overflow and condensate
<i>Tank displays “▪READY” when filled & 200°F/93°C is reached</i>	
Brewer is ready to brew when “▪READY” is displayed	-Best results if brewer remains “ON”

Operating Instructions

→To brew a single coffee batch, using default recipe







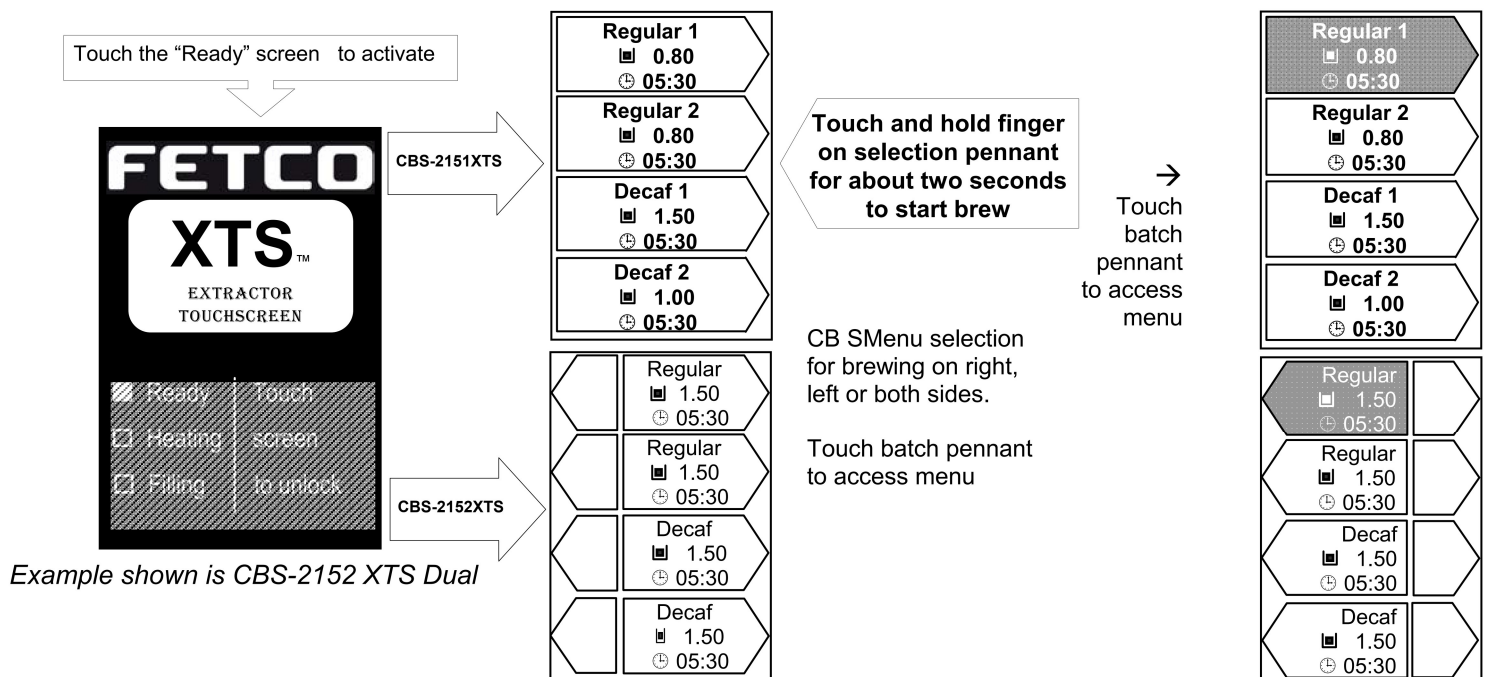

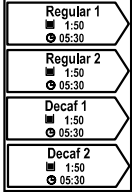
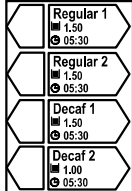

NOTES

All CBS-2150xts series brewers are factory calibrated and preloaded with recipes and are ready to brew.

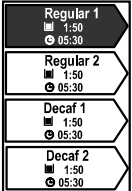
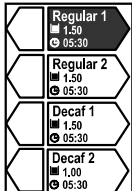
Place paper filter in brew basket	<p>-Use any quality pleated filter paper CBS-2150XTS Coffee Filters: 15” X 5 ½”</p> <p>-Brewbasket(s) must be in place</p> <p>-Use the convenient locator guide</p> <p>-A long duration “TAP” with fingertip</p> <p>-Touch batch pennant with fingertip</p> <p>-Icon may be toggled for information</p> <p>-Right to left side switching by touch</p> <p>-Brew time: 4 minutes+1½ min. drip out</p>
Add ground coffee	
Insert loaded brewbasket into brewer rails	
Have empty dispenser under brewbasket	
Tap “▪ READY” screen to enter the batch selection menu	
Touch a top batch key for “REGULAR 1”	
Brewer will brew and display the icon for the function step it is in	
For dual side brewer, touch other side to access and activate the second side batches for brewing	
Batch will complete brewing in 5 ½ minutes	

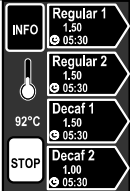
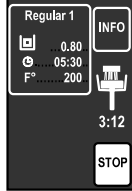
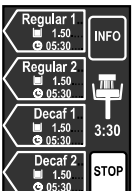
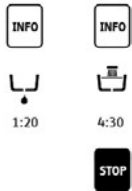

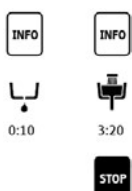
Brewing-shown by touchscreen

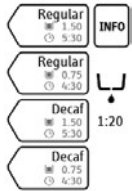
Brewer screens displayed for brewing		NOTES
<p>CBS-2151XTS SINGLE SIDE</p>  <p>“READY SCREEN” Tap screen to display menus</p>	<p>CBS-2152XTS TWIN SIDE</p> 	<p>Note: There are three “BREW AT TEMPERATURE DEFINITONS”. The “<i>Brew At Temperature</i>”—“ON” default routine is used for the illustration below..</p>
 <p>Unit displays four preprogrammed batch buttons per side. CBS-2152XTS has right and left ←CBS-2151XTS single side CBS-2152XTS dual side→</p>		<p>Brew at tempertaure “ON” enabled: if this feature is enabled:brew start will be enabled when tank temperature reaches the temperature set point</p> 
 <p>Select and hold one button for 2 seconds</p>		<p>If pressed in ON: Brew activation screen “locks out” until tank is at set temp.</p>  <p>If pressed in “AUTO” Brew At Temperature Setting, a WAIT screen with temperature icon appears . Brew will start when tank is at set temperature</p> 
 <p>Brewing ←CBS-2151XTS single side CBS-2152XTS dual side→</p>		<p>Both sides of a dual side CBS-2152XTS brewing simultanously, brewer sides will also operate independently or alone</p> 
 <p>Brew completed (in drip delay) ←CBS-2151XTS single side CBS-2152XTS dual side→</p>		<p>Both sides of a dual side CBS-2152XTS brewing simultanously. Left side completing drip delay</p> 
<p>Brew basket sensor enabled. Unit is brewable only when brebasket is in place. (option may be disabled by user)</p>		<p>CBS-2152XTS dual side right side completing drip delay, left side ready for next brew</p> 

Programming- operator access programming

- The FETCO CBS-2150XTS brewers have four brew batch menus per side.
- Menus are preprogrammed by the factory with basic settings that will operate the equipment as purchased.
- There are two batches each marked “Regular” and two marked “Decaf”
- Most operators prefer a full batch and half batch setting for regular and decaf or specialty coffees.
- The half batch setting will need to be programmed by the operator to match the dispenser.
- Settings are adjustable and the name of the menu can be changed. -Batch 1 & 4 cannot be disabled.

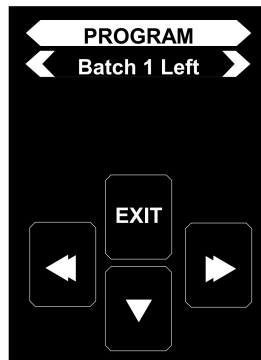
Menu screen displayed	Accessing Programming	Menu screen displayed	Accessing Programming menu screens
 <p>(Brewer “HOME” screen)</p>	Turn unit “OFF” After 10 second delay: Turn unit “ON” ← “HOME” Screen on left will appear Immediately place finger on screen and “HOLD” Screen on right will appear →	 <p>(Programming menu screen)</p>	← Top line is programming category ← Second line displays items for programming Right and left hand arrows will scroll to the screens that display “Program, General, Inputs, Outputs and Other” The down arrow enters the individual programming items shown below

Programming-category screens: Menu Tree

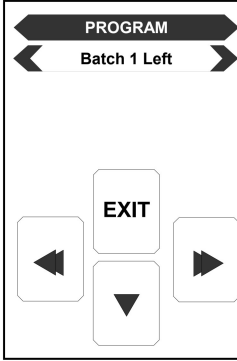
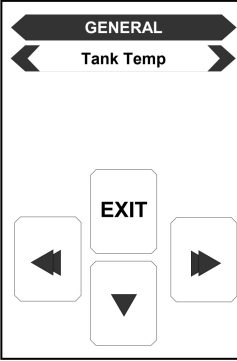
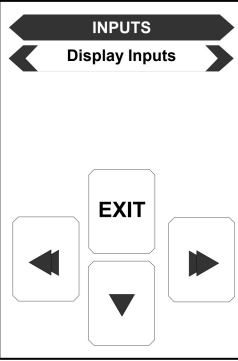
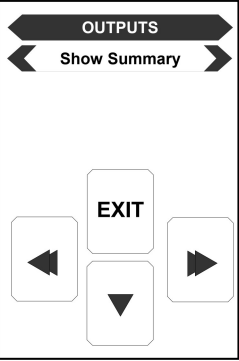
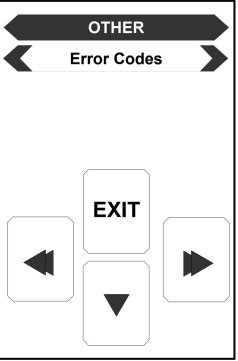
Programming category screens				
To enter: Turn unit “OFF”, After 10 second delay, turn unit “ON”, (Home Screen will appear), Immediately place finger on screen and “HOLD”—“PROGRAM” Screen (first below) will appear. Use right/left and down arrows to travel through programming. “EXIT” saves settings				
				
Programming Category	Programming Category	Programming Category	Programming Category	Programming Category
PROGRAM	GENERAL	INPUTS	OUTPUTS	OTHER
Items for Programming	Items for Programming	Items for Programming	Items for Programming	Items for Programming
Batch 1 Left*	Tank Temp	Display Inputs	Show Summary	Error Codes
Batch 2 Left**	Brew At Temp	Calib Touch Scr	Left Valve	Copy Program
Batch 3 Left **	Units of Meas.		L. Bypass Valve	Upload Logo
Batch 4 Left **	ECO Mode		Right Valve	Res to Factory
Batch 1 RIGHT*	Logo Timeout		R. Bypass Valve	Counters
Batch 2 Right **	Brew B.Sensor		Fill Valve	Firmware
Batch 3 Right **	Use Flojet		Left Basket Lk	DEMO Mode
Batch 4 Right **	LLC Sensitivity		Right Basket Lk	
Batch Copy			Heater	
			Screen	

Menu Features: Batch Parameters

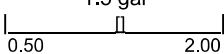
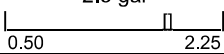
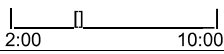
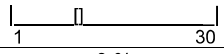
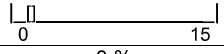
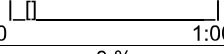
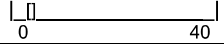
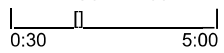
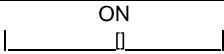
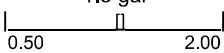
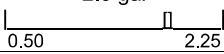
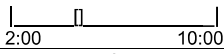
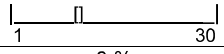
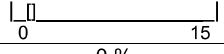
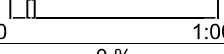
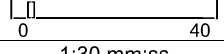
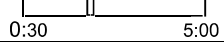
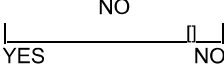
PROGRAM	Programming Items	Factory set Default	Programming Range	Notes
Batch 1 LEFT*	• Batch Summary	Display Summary		
	• Batch Name	Regular 1(-16)	Choose from list: Regular1	(Regular 1-16) -OR- Write: any name
CBS-2151& 2152XTS 1 ½ Gallon	• Batch Volume	1.50 gal [0.50-2.00]	1.50 gal 	
	• Batch Volume	2.00 gal [0.50-2.25]	2.50 gal 	
	• Brew Time	4:00 mm:ss [2:00-10.00]	4:00 mm:ss 	
	• Nr Of Pulses	8	8 	
	• Prewet Perc.	0%	0 % 	
	• Prewet Delay.	0%	0 % 	This feature appears ONLY if Prewet >0:00
• Bypass Perc.	0%	0 % 	•	
	• Drip Delay	1:30 mm:ss	1:30 mm:ss 	
Batch 2 Left**	**Batch 2-4—Right and Batch2-4—Left may be individually selected-or-entirely deleted			
	• Batch ON/OFF	ON	ON 	
	• Batch Summary	Display Summary		
	• Batch Name	Regular 1	Regular 1-16;Write own name	
CBS-2151& 2152XTS 1 ½ Gallon	• Batch Volume	1.50 gal [0.50-2.00]	1.50 gal 	
	• Batch Volume	2.00 gal [0.50-2.25]	2.50 gal 	
	• Brew Time	4:00 mm:ss [2:00-10.00]	4:00 mm:ss 	
	• Nr Of Pulses	8	8 	
	• Prewet Perc.	0%	0 % 	
	• Prewet Delay.	0%	0 % 	This feature appears ONLY if Prewet >0:00
• Bypass Perc.	0%	0 % 		
	• Drip Delay	1:30 mm:ss	1:30 mm:ss 	
Batch 3 Left **	<i>(See Batch 2-Left)</i>			
Batch 4 Left **	<i>(See Batch 2-Left)</i>			
Batch 1 Right *	<i>(See Batch 1-Left)</i>			
Batch 2 Right **	<i>(See Batch 2-Left)</i>			
Batch 3 Right **	<i>(See Batch 2-Left)</i>			
Batch 4 Right **	<i>(See Batch 2-Left)</i>			
Batch Copy	Copy From Batch	L1	L1-L4;R1-R4	
	Copy To Batch	L1	L1-L4;R1-R4	
	Copy?	L1→L2? (example)	NO 	

*Batch 1&4 cannot be disabled. (CBS-2152XTS); *Batch 1 cannot be disabled. (CBS-2151XTS) **Batch can be disabled, and removed from display

GENERAL	Programming Items	Factory set Default	Programming Range (display)	Notes
Tank Temp.		200°F		Chart to correct for high altitude below
Brew at Temp.	“OFF” allows brewing at any temperature.	“ON”		SEE NOTE BELOW!
Units of Meas.	• Temperature	°C or °F		[Switchable Units]
	• Volume	Gallons [Liters]		[Switchable Units]
ECO Mode	Energy Saving Mode	OFF		If Selected: Lowers hot water tank temperature to 170°F after 1 hour of inactivity
Logo Timeout		0:30 mm:ss		
Brew B. Sensor		NORMAL (SEE WARNINGS)		Factory or service use for servicing. “NORMAL” is recommended for safety.
Use Flowjet		NO		Trims water handling system for Flowjet
LLC Sensitivity*	Normal for most water “HIGH” for R.O.	NORMAL		Liquid level control sensitivity. High is for reverse osmosis water or very pure water.

Most water has sufficient mineral content for proper brewer refill cycling. If refill is erratic, inspect all wiring and if “ERROR CODE 107” displays, or if water is tested to be very pure (<100 TDS or 5.5 grain), set LLC to “HIGH”.

BREW AT TEMPERATURE DEFINITONS

BREW AT TEMP: “ON”

(DEFAULT: FACTORY PROGRAMMED INTO BREWER)

“BREW START” Batch Section Buttons will not be accessible until tank temperature is at set point.

The “BREW START” screens with the Batch Section Buttons become accessible when hot water tank is at the selected temperature. A screen (example to the right) will display showing “BREW AT TEMP” is selected. →

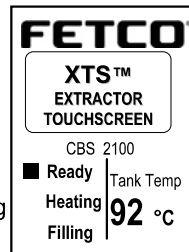

BREW AT TEMP: AUTO

USER SELECTABLE

“BREW START” will pause if the hot water tank is not at the selected temperature—and automatically start when it is at the set temperature.

If the temperature is too low, the brewer will wait until the proper temperature is reached. A screen (example to the right) will display showing a thermometer icon and the tank temperature →.

IMPORTANT: ALWAYS have dispenser(s) under the brewer when in the BREW AT TEMP mode

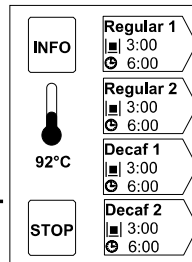

BREW AT TEMP: OFF

USER SELECTABLE (Not recommended)

Allows brewing at any temperature above 170°F/77°C.

Chart to correct for altitude for boiling point in tank water temperature.

[ft]	[m]	Suggested Setting[°F]	Boiling point[°F]	Suggested Setting[°C]	Boiling point[°C]
0	0	205	212.0	96	100.0
500	152	205	211.0	96	99.5
1000	305	200	210.1	93	98.9
2000	610	200	208.1	93	97.8
2500	762	200	207.2	93	97.3
3000	914	200	206.2	93	96.8
3500	1067	197	205.3	92	96.3
4000	1219	195	204.3	91	95.7
4500	1372	194	203.4	90	95.2
5000	1524	194	202.4	90	94.7
5500	1676	193	201.5	89	94.2
6000	1829	192	200.6	89	93.6
6500	1981	191	199.6	88	93.1
7000	2134	190	198.7	87	92.6
7500	2286	188	197.8	86	92.1
8000	2438	187	196.9	86	91.6
8500	2591	185	196.0	85	91.1

ECO MODE-Energy saving mode DEFINITONS

If Selected: Turns heaters off after 1 hour of inactivity.

The hot water tank temperature will slowly decline to no lower than 60°C/170°F

A screen (example to the right) will display showing “ECO Mode” is activated. →

To return from ECO-Mode

Tap the screen, ECO Mode turns off, and the brewer will heat to set temperature.

It takes approximately 7-15 minutes to return from 60°C/170°F to factory default 93°C/200°F

All FETCO commercial hot beverage equipment have well insulated hot water tanks and have engineered mechanical features to limit energy consumption.

Effective construction and insulation increases equipment life and lowers building HVAC costs.

FETCO hot beverage equipment have the best energy savings of all major suppliers.

FETCO™

XTS™
EXTRACTOR
TOUCHSCREEN

CBS_2100XTS









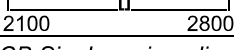

ECO

Heating
Filling

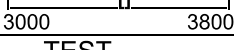
89°C

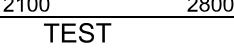
INPUTS	Programming Items	Factory set Default	Programming Range (display)	Notes
Display Inputs	• Input Summery		R. Brew Basket Sens. [single/dual] <input type="checkbox"/> L. Brew Basket Sens. <input checked="" type="checkbox"/> H. Liquid Level probe <input checked="" type="checkbox"/> H. Tank Temperature Probe <input checked="" type="checkbox"/> L. Tank Temperature Probe <input checked="" type="checkbox"/> SD Card Recognized <input type="checkbox"/> Tank Temp. 200	
Cal. Touch Scr		Calibrate	Calibrate _____ YES NO	If Yes: Follow directions on the touch screen

INPUT SUMMARY SCREEN	
Display Inputs (See "INPUTS" Service Screen)	Brew Basket Sensor <input checked="" type="checkbox"/> High Liquid Level Probe <input checked="" type="checkbox"/> Low Liquid Level Probe <input checked="" type="checkbox"/> Tank Temp. Probe <input checked="" type="checkbox"/> SD Card present <input type="checkbox"/> Tank Temperature 205F
Use DISPLY INPUTS screen to assist in error code fault correction. There are two liquid level probes shown as High and Low High is the fill volume of the hot water tank Low probe is the level when the heaters are sufficiently covered by water to start.	

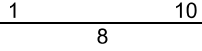
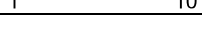
OUTPUTS	Programming Items	Factory set Default	Programming Range (display)	Notes
Show Summary	• Output Summary		Left Brew FR 3400 Left Bypass FR 2400 Right Brew FR 3400 Right Bypass FR 2400 Screen Contrast 8 Screen Brightness 8 Touch To Return	FR=Flow Rate ml/min
Left Valve Test OR Calibrate	• Left Valve Test	(Press to test)	TEST Press To Test 	Runs valve to verify flow. Have container under brewbasket!
” ” ” ”	• L. Valve Calib	Calibrate *Flow Rate	3400 ml p m 	Factory or service use for flow rate
L. Bypass Valve Test OR Calibrate Not on CBS 2130XTS	• Left Bypass Valve Test	(Press to test)	TEST Press To Test 	Runs valve to verify flow. Have container under brewbasket!
” ” ” ”	• L. Bypass Valve Calib	Calibrate *Flow Rate	2400 ml p m 	Factory or service use for flow rate
<i>Left Valve display is only for BCB Series- dual station brewer. BCB Single series displays RIGHT SIDE only</i>				
Right Valve Test OR Calibrate	• Right Valve Test	(Press to test)	TEST Press To Test 	Runs Valve to verify flow. Have container under brewbasket!
” ” ” ”	• R. Valve Calib	Calibrate *Flow Rate	3400 ml p m 	Factory or service use for flow rate
R. Bypass Valve Test OR Calibrate Not on CBS 2130XTS	• Right Bypass Valve Test	(Press to test)	TEST Press To Test 	Runs valve to verify flow. Have container under brewbasket!
” ” ” ”	• R. Bypass Valve Calib	Calibrate *Flow Rate	2400 ml p m 	Factory or service use for flow rate
Fill Valve	• Fill Valve Test	(Press to test)	TEST Press To Test 	Operates fill valve. Have container under both brewbaskets!
Left Basket Lk. Not on CBS 2130XTS	• Left brew basket lock test	(Press to test)	TEST Press To Test 	Energizes brew basket lock. For factory or service use
Right Basket Lk. Not on CBS 2130XTS	• Right brew basket lock test	(Press to test)	TEST Press To Test 	Energizes brew basket lock. For factory or service use
Heater	• Heater Test	(Press to test)	TEST Press To Test 	Energizes Heater(s) Use for servicing.
Screen Brightness OR Contrast	• Screen Contrast	Contrast	8 	
	• S. Brightness	Brightness	8 	

For factory or qualified service professional use only

How to calibrate the flow rate

Set the flow rates of components to adjust for taste profile and for over or under potting.

Built-in algorithms in Brewer controller software corrects brew parameter to customer preferences or to trim variations in flow control components

NOTICE: This operation requires operator hold finger on keypad position for one minute—without lifting it.

1) MEASURE THE FLOW RATE:

- Enter programming mode, scroll left to “OUTPUTS”
- Scroll down to “Left(or)Right Valve Test”
- Place 5 liter/2gal measuring container under empty brewbasket.
One good way to measure is to weigh the test water. Use a scale for at least 5 kg/12lb
- Press To Test the Brew Valve. **→! Keep finger on touchpad for one minute! !!DO NOT STOP!!**
It is very important for this test to keep finger in place for the entire minute.

Measure the results of the flow in the 5-liter measuring container and hold the number.

2) **AUTOMATIC** Built-in CALIBRATE THE FLOW RATE

- Enter this number, in milliliters, into the calibration slider for the Valve tested in the OUTPUT MENU.
- Use milliliters.** If measured in fluid ounces (fl.oz) multiply by 29.57 to convert to milliliters
- After entering the measured volume, exit PROGRAMMING and return to the normal screens

3) **MANUAL METHOD** Operator input: CALIBRATE THE FLOW RATE

Use the amount measured, in milliliters, divided by programmed value and multiply by the current setting



← Example of CBS-2150 brew valve slider

$$\frac{\text{Actual Volume}}{\text{Programmed Volume}} \times \text{CURRENT SETTING} = \text{NEW SETTING}$$

Enter new setting on the slider shown and EXIT to save

Obtain programmed volume from “PROGRAM” Menu under “Batch Summary”.

Note—match correct batch number to correct side, if two sided.

By entering the new flow rate number into the brewer, the software automatically corrects the valve flow discrepancy

Hot water convenience tap

1. The XTS_Series coffee brewers include a hot water convenience tap for single cup beverage purposes.
2. Single use delivery volume should not exceed maximum 16fl.oz/473cc.
3. Water dispensed from this faucet is very hot, up to 205°F/96°C



OTHER	Programming Items	Factory set Default	Programming Range (display)	Notes
Error Codes	• Display Errors	(Codes)	1: 2: 3:	See Error Code Chart for references
	• Reset Errors	(Reset)	Reset ----- YES NO	!!Errors must be corrected and cleared!!
Copy Program	• From SD to B.	SD → Brewer	SD → Brewer ----- YES NO	Setup upload Please insert SD card with the setup data!
	• From B to SD	Brewer → SD	Brewer → SD ----- YES NO	Setup download Please insert SD card with sufficient space (≥2GB)
Upload Logo		Upload Logo	UPLOAD LOGO Are you sure ----- YES NO	Please insert SD card with logo file!
Res to Factory & Select Brewer Type	See next line: “Select Brewer Configuration”	Reset to default	Reset to Default Are you sure ----- YES NO	Completely overwrites all user setup, incl. user logo.
Select Brewer Configuration	CBS_2131 3L; CBS_2131 1G CBS_2132 3L; CBS_2132 1G CBS_2141; CBS_2142 CBS_2151; CBS_2152	Screen appears after pressing “Res to Factory” [Above]	Select Model CBS [2131-2152]Series -----	Scroll to your brewer and tap ENTER tab 
Counters	• Display Counters -OR- • Display Resettable Counters	Counters Display Total Counters	Total Counters Left Brews 0 Left Brew activated 0 Left Brew [gal] 0 Left Bypass activated 0 Left Bypass [gal] 0 Right Brews 0 Right Brew activated 0 Right Brew [gal] 0 Right Bypass activated 0 Right Bypass [gal] 0 Fill valve Activated 0 Fill Valve [gal] 0 Heater Activated 0 Heater “ON” time 0:00 Touch To Return	Identical screen for Resettable Counters Will display when selected. See next line to reset to zero NOTE: “Total Counters” is not user resettable
Reset Counters	• Resets Counters	Reset All Counters	Reset All Counters Are you sure ----- YES NO	Resetting will restart counter from zero
Firmware	• Firmware Version -Software type	Display Firmware Version	CBS_2152 [or model type] SW ver 2.1.0Z HW ver 1.1.3 QP ver. 4.5.01	Displays firmware version
	• Update Firmware	UPDATE	UPDATE ----- YES NO	Firmware upload Please insert SD card with the firmware file!
DEMO Mode	DEMO ON/OFF		OFF ----- ON OFF	Demonstrates the controls for training. Disables all components in demo mode.

Safety Notes

1. Professional installation is required. This appliance is manufactured only for commercial use.
2. Operation requirements and maintenance for commercial cooking appliances differ from household appliances.
3. Operators must be trained for this equipment and must understand the use, maintenance and hazards.
4. Access to the service area is restricted to persons having safety/hygiene knowledge and practical experience of the coffee brewer. This appliance must be installed in locations where it can be overseen by adult trained personnel.
5. Do not attempt to move hot beverage equipment once it is filled. Drain equipment before moving.
6. FETCO commercial coffee brewers prepare large amounts of coffee or tea in a single batch using very hot water
7. Commercial coffee brewers provides very hot water from the sprayhead, brewbasket and faucet when it is pulled.
8. Coffee brewers may continue to dispense very hot water from the mechanically operated faucet after the electronic touchpad is completely disabled by turning off the power switch on the lower back of the unit, or unplugging the unit.
9. For safety, the brewer control locks the brew basket for 5.5 minutes after starting the brew.
10. Never attempt to defeat the factory set (default) time that the brew basket is locked for safety from start of brew.

Keep these instructions for training and future reference

Error Codes

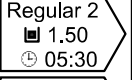
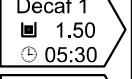
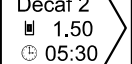
→Contact specialized personnel for error codes				
Code	Description	Possible Cause	Corrective Action	How to Clear Error Codes
001	Software error-error on start up or corrupted software	Improper start-up or shutdown	Restart , if still fault: reload software	<p>TO CLEAR FAULT, Make repairs as required</p> <p>Below is the only way to clear error codes</p> <p>1) Enter "PROGRAMMING"</p> <p>2) Scroll left to "OTHER"</p> <p>3) Scroll down to "ERROR CODES"</p> <p>4) Scroll down to "Display Errors"</p> <p>5) Scroll left to "Reset Errors"</p> <p>6) Scroll down to "Reset"</p> <p>7) Follow directions shown on screen.</p> <p>Merely toggling ON/OFF switch <u>will not</u> clear error codes.</p> <p>Error codes must be cleared by entering PROGRAMMING and using the menus!</p>
050	Shorted temperature probe	Probe failure.	Replace probe.	
051	Open temperature probe.	Bad probe connection, or probe failure.	Check all connections. Replace probe if necessary.	
100	Initial Fill Error. Initial fill time was more than 4 minutes after power up.	Water supply flow rate is too low.	Watch for short potting during brew cycle. Investigate cause of low flow rate. (Clogged water filter...)	
101	Error on refill Tank did not refill within 3 minutes.	Water supply flow rate is too low.	Watch for short potting during brew cycle. Investigate cause of low flow rate. (Clogged water filter...)	
102	Unwanted fill;	Possible leak in tank, fitting, or valve.	Check inside of machine for leaks.	
103	Liquid level probe fault	Probe fouled or shorts	Clean, check all connections. Replace probe if necessary.	
107	Lower liquid level probe Fault	-Tank not filling -Orange wire to temperature probe disconnected -Very pure water	Occurs after prefill -Low probe is uncovered -Wires are reversed -Set LLC sensitivity to HIGH see MENU—GENERAL-LLC	
201	Heater open, high limit thermostat, or Solid State Relay (SSR) fault	Failure of: heating element, SSR, high Limit or low voltage	Check and replace heating elements if necessary.	
255	Touch pad error	Usually from longer than 2 min touch contact. Or faulty reassembly after service	Restart , if still fault: reload software. If mechanical: reassemble correctly	
 INSERT BREW BASKET		 INSERT BREW BASKET		
   		Brewbasket must be in place	Insert brewbasket	

! → Never attempt to defeat or override a brew basket-locking feature.

Operator Training

Review the operating procedures with whoever will be using the brewer.

Pay particular attention to the following areas:

1. Always pre-heat the dispensers before the first use of each day by filling them half way with hot water, and letting them stand for at least 5 minutes.
2. Do not remove the brew basket from a coffee brewer until it has stopped dripping.
3. Make sure the dispenser is empty before brewing into it.
4. Show how to attach covers, close, and or secure the dispensers for transporting.
5. Show the location and operation of the water shut off valve as well as the circuit breaker for the brewer.
6. Steam from the tank will form condensation in the vent tubes. This condensation will drip into and then out of the brew baskets. Up to 1/4 cup/118cc discharging overnight is possible. Place an appropriate container under each brew basket when not in use.
7. We recommend leaving the power to the brewer on overnight. The water tank is well insulated and very little electricity is used to keep the tank hot. Leaving the brewer in the "ON" position will also avoid delays at the beginning of shifts for the brewer to reach operating temperature.

Cleaning & Maintenance

After Each Brew:

1. Dispose of grounds and rinse brew basket.
2. Never strike a brewbasket or hit it against a hard surface.
This will damage the brew cone, and may damage the brewbasket support rails
3. Rinse dispensers before reuse.

Every Day:

1. Wash brew basket with hot sudsy water.
2. Pull CSD from the spray head, it is magnetically attached. Use gloves or a heavy towel. → Wash off any film and reattach. Use vinegar if limescale filming is present.
3. Clean dispensers with hot suds water and a brush, rinse and air dry.
4. Use only a soft cloth and hot suds on the outside to avoid scratches. Never use abrasives that will scratch surface.

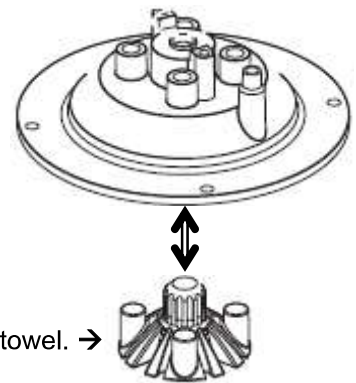

Weekly

1. Use a commercial coffee dispenser cleaner such as URNEX™, TABZ™, DIP-IT™ or Squeak 'n Clean™.
2. Carefully Follow the instructions supplied with the cleaning product
3. Never use spray cleaners, solvent, solvent based cleaner or petroleum based polish anywhere on dispensers

Warning

1. Turn off power before any cleaning procedure, including wiping the exterior for appearance reasons.
2. Dry the exterior, especially the face panel, before turning on power.
3. Do not apply any type of spray cleaner on the face panel of this equipment.
4. Never use solvent or solvent-based cleaner or petroleum based polish anywhere on this equipment.
5. Dry the face of the touch pad before turning on power
6. Do not electrically energize this equipment or attempt operation without all covers in place and all screws fastened.
7. Unplug machine before disassembly or servicing.

Service Guide to a Successful Installation

(For Qualified Service Technicians Only)

If not installed correctly by qualified personnel, the brewer will not operate properly and damage may result. Damages resulting from improper installation are not covered by the warranty, and will void the warranty. Here are the key points to consider before installation:

Electrical:

1. All CBS_Series brewers require **an electrical ground wire**. Installation without grounding is dangerous.
2. Note Equipotentiality Terminal, if present, (To identify the terminals which, when connected together, bring the various parts of an equipment or of a system to the same potential, not necessarily being the earth (ground) potential, e.g. for local bonding.)
3. Verify voltages, polarity, circuits, and circuit breaker access before attaching equipment.
4. The electrical diagram is located in the Users Guide and online at www.fetco.com.
5. Make sure of the tight grounding of the equipment and use the external ground bolt.
6. The installation must comply with applicable federal, state, and local codes having jurisdiction at your location. Check with your local inspectors to determine what codes will apply.

Plumbing:

1. North America: All installations must comply with applicable federal, state, or local plumbing codes.
2. All Others: The water and waste piping and connections shall comply with the International Plumbing Code 2003, International Code Council (ICC), or to the Uniform Plumbing Code 2003 (IAPMO).
3. Use an inline water filter for all beverage equipment.
Install the filter unit after a water shutoff valve and in a position to facilitate filter replacement.
4. The water line and newly installed filter cartage must be flushed thoroughly prior to connecting it to the brewer to prevent debris from contaminating the machine.
5. Verify that the water line will provide a flow rate of at least 1½gpm/ (5.7lpm) per minute and the water pressure is between 20-75 psig (138-517kPa) before making any connections.
6. Install a backflow prevention device. Most municipalities require a recognized backflow preventer.
7. Usable on all hot beverage and cold beverage equipment is a WATTS® SD-2 or SD-3.
8. WATTS spring loaded double check valve models are accepted by most zoning authorities.
9. →The check valve should be as close to the water supply inlet of the beverage equipment as possible.

General:

- ❖ Utilize only qualified beverage equipment service technicians for service and installation.
- ❖ Always have an empty dispenser under sprayhead of all coffee brewing equipment-including when at idle

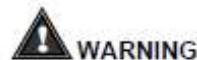
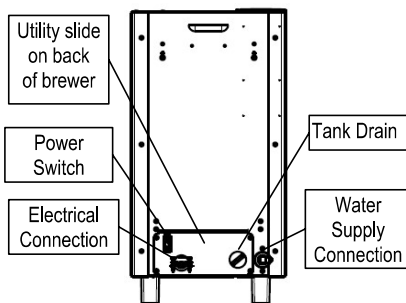
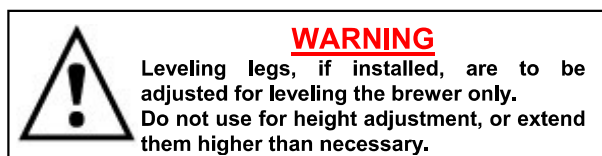

All electrical connections must be in accordance with local electrical codes and any other applicable codes.

If the supply cord is damaged, it must be replaced by the manufacturer, its service agent, or similarly qualified persons in order to avoid a hazard.

To prevent an electric shock hazard this device must be bonded to equipment in close proximity with an equipotential bonding conductor. This device is equipped with a grounding lug for this purpose and is marked with the following symbol



Installation Directions

For professional installation only

Brewer Setup

1. Review the dimensions for the unit and verify that it will fit properly in the space intended for it. Verify that the counter or table will support the total weight of the brewer and dispensers when filled (specifics-page 23).
2. Place the brewer on the counter or stand
3. For terminal block electrical connected units: remove the lower utility slide out at the back of the equipment to access the electrical connections. The utility slide must remain close to the unit.
Note: Utility slide out panel cannot be completely detached from the brewer.
4. Access to the service area is restricted to persons having safety/hygiene knowledge and practical experience of the coffee brewer. This appliance must be installed in locations where it can be overseen by trained personnel
5. For proper operation, this appliance must be installed indoors where the temperature is between 10°C/50°F to 35°C/95°F. Drain and remove all liquid from equipment and lines if exposed to freezing temperatures
6. All commercial cooking equipment, including this unit, is not intended for use by children or persons with reduced physical, sensory, or mental capabilities. Ensure proper supervision of children and keep them away from the unit.
7. All commercial cooking equipment, including this unit, is not intended for use by children or persons with reduced physical, sensory, or mental capabilities. Ensure proper supervision of children and keep them away from the unit
8. This unit must be installed and serviced by qualified personnel only.
9. Installation must conform to all local electrical and plumbing codes. Installation by unqualified personnel will void the unit warranty and may lead to electric shock or burn, as well as damage to unit and/or its surroundings.
10. Review the dimensions for the unit and verify that it will fit properly in the space intended for it. Verify that the counter or table will support the total weight of the brewer and dispensers when filled (See: Technical Data).
11. Place the brewer on the counter or stand. When the brewer is in position, level it front to back as well as side-to-side by adjusting the legs.
12. Do not tilt appliance more than 10° to insure safe operation.
13. Unit is for protected indoor use only. Do not steam clean or use excessive water on unit.
14. This unit is not "jet-proof" construction. Do not pressure wash or use jet spray to clean this unit.
15. The unit is not waterproof-do not submerge or saturate with water.
Do not operate if unit has been submerged or saturated with water.

Equipment exposed to flood and contaminated must never be used due to electrical and food safety.

General:

Utilize only qualified beverage equipment service technicians for installation.

A Service Company Directory may be found on our web site, <http://www.fetco.com>.

Water Connection

1. This equipment is to be installed to comply with the applicable federal, state, or local plumbing codes.
2. Water supply inlet is a 3/8 inch male flare fitting
3. The brewer can be connected to a cold water line.
4. Install a shut off water valve near the brewer to facilitate service.
5. An in-line water filter should be used. Install filter unit after the water shut off valve and in a position to facilitate filter replacement.
6. Flush the water supply line and filter **before** connecting it to the brewer.
7. Verify that the water line will deliver a flow rate of at least 1½gpm/(5.7lpm) per minute and water pressure is between 20-75 psig (138-517kPa) before making any connections.
8. Use a wrench on the factory fitting when connecting the incoming water line. This will reduce stress on the internal connections and reduce the possibility of leaks developing after the install has been completed









Electrical-General

1. All FETCO brewers require Ground. Installation without ground may cause a hazard.
2. The electrical diagram with universal wiring instructions is located on the inside of the lower cover.
3. The installation must comply with applicable federal, state, and local codes having jurisdiction at your location. Check with your local inspectors to determine what codes will apply

Electrical Connection

1. The CBS-2100XTS series models requires hardwire to the terminal block to a, grounded service
2. Verify that the actual voltage at the electrical service connection is compatible with the specifications on the brewer's serial number label. Make sure the electrical service match the current draw of the equipment.
3. All CBS-2150XTS have a terminal block for connecting the incoming power wires. Consult local codes to determine if a cord and plug can be installed on factory supplied terminal block equipment, or if the unit must be hard wired.
4. Access the terminal block for electrical connection by removing the pullout service module on the lower back.
5. A fused disconnect switch or circuit breaker on the incoming power line must be conveniently located near the brewer, and its location and markings known to the operators.
6. The temperature and water tank fill level are pre-set at the factory. There is no need to turn off the heaters during the installation process. The heaters are disabled by the control board until the tank is full of water. The heating process will start automatically when the tank has filled.
7. The body of the brewer must be grounded to a suitable building ground.
8. If Cord Connected: Do not use multiple taps for the plug. Consult local codes to determine if a single circuit is required for the cord and plug installed. Do not use extension cords for commercial food equipment.
9. All covers, removable panels and electrical connections must be secured in-place within the unit to meet national and local standards.

See wiring diagrams in back of user guide for connections

	WARNING To reduce risk of electric shock or fire.
	FETCO® Hot Beverage Equipment is for commercial use only.
	Do not remove or open cover. No user serviceable parts inside. Refer installation and service to qualified personnel.
	Caution, disconnect from power supply before servicing.
	GROUND: National Electrical Code requires separate grounding wire.
	Use dedicated circuit with capacity rated by local code or National Electrical Code for the current draw of this equipment. Check serial number plate on right side for power requirements.
	Locate unit away from source of heat. Do not install or use near combustibles.
	THIS APPLIANCE IS ENERGIZED WHENEVER IT IS CONNECTED TO A POWER SOURCE
	FAILURE TO COMPLY RISKS EQUIPMENT DAMAGE, PROPERTY DAMAGE, FIRE, OR SHOCK HAZARD
Notice	This equipment must be installed with a backflow protection device to comply with federal, state or local municipality codes.
Notice	Read the user guide before installing and operating this unit.

Technical Data—CBS-2150XTS 1½ gallon single and dual brewers
Capacities & Measurements for single and dual brewers
CBS-2150XTS Dimensions & Utility Connections
CBS-2150XTS Rough-in Drawings

Brewer	Height	Width	Depth	Empty Weight	Filled Weight	Total Weight- Brewer & Full Dispenser	Hot Water Tank Capacity	Shipping Weight	Shipping Dimensions
CBS-2151XTS Single-1½ gallon	36 ¾" 933mm	12 ¾" 324mm	20 ¾" 518mm	53lb 24kg	106.5lb 48.3kg	129.5lb 58.7kg	6.4 gal 24.3 l	57lb 26kg	17"x 20" x 35" 431x508x889mm
CBS-2152XTS Dual-1½ gallon	36 ¾" 933mm	21 ¾" 552mm	20 ¾" 518mm	77lb 35kg	174lb 78.7kg	220lb 99.8kg	11.5 gal 43.7 l	90lb 41kg	22"x 27" x 35" 559x686x889mm
CBS-2152XTS Dual-2 gallon	38 ⅞" 986mm	21 ¾" 552mm	20 ¾" 518mm	82lb 37kg	180lb 81.6kg	234lb 106.3kg	11.5 gal 43.7 l	96lb 43.5kg	22"x 27" x 37" 559x686x940mm

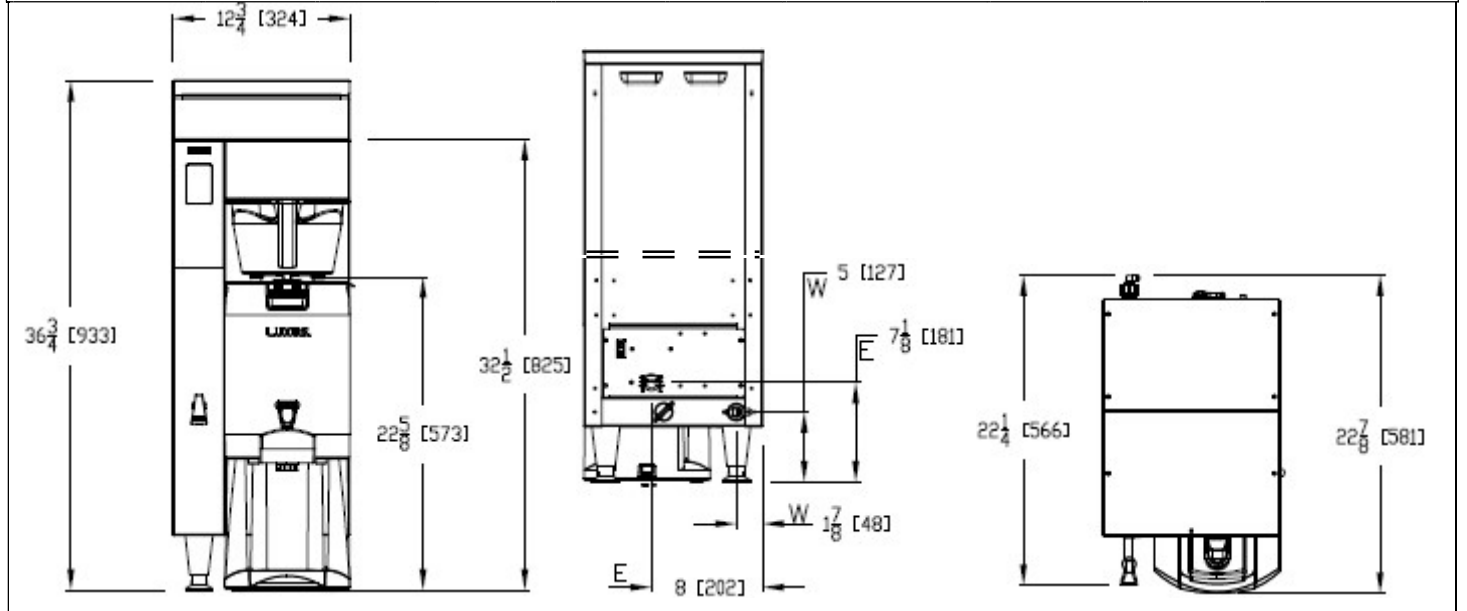

Rough-in CBS-2151XTS —Single station version

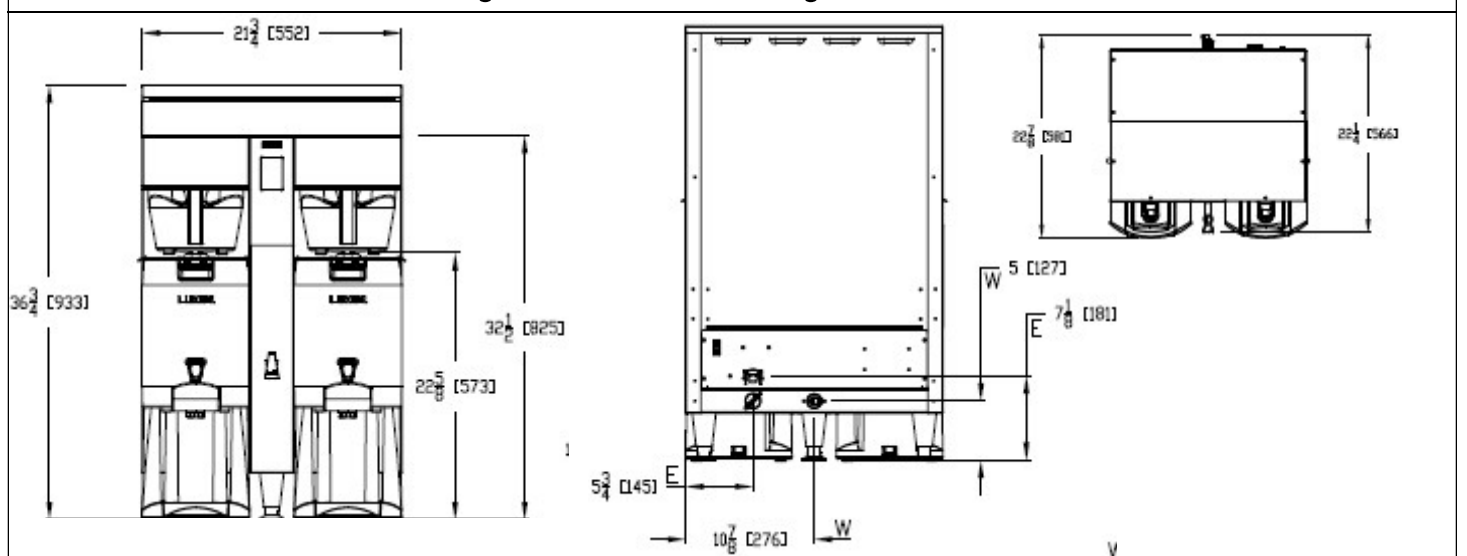

Rough-in CBS-2152XTS —Dual station version

CBS-2150XTS Utility Requirements

- ❖ **Water Requirements:** 20-75 psig (138-517kPa) 1½gpm/(5.7lpm)
- ❖ **Water inlet fitting** is a 3/8 inch male flare.
- ❖ **Inlet Water Temperature:** Cold supply
- ❖ **Coffee Filter Size:** →CBS-2150XTS: 15" X 5 ½"
- ❖ **Electrical:** See electrical configuration chart

CBS_2151XTS—Single 1½ gallon version Electrical Configurations

Configuration Code		Heater Configuration	Voltage	Phase	Wires	Electrical Connection	KW	Amp Draw	Gallon/Hour (1½ gallon per batch)
Plastic Brewbasket	Stainless Steel Brewbasket								
E215151	E215151M	2 X 3.0 kW	208-240	1	2+G	Hardwired	4.6-6.1	22.4-25.8	15.3 gal/58 liters

Configuration Code		Heater Configuration	Voltage	Phase	Wires	Electrical Connection	KW	Amp Draw	Gallon/Hour (1½ gallon per batch)
Plastic Brewbasket	Stainless Steel Brewbasket								
E215190	E215190M	1 X 4.0 kW	200-240	1	2+G	Hardwired	4.1	14.2-17.1	9.3 gal/35 liters
E215191	E215191M	1 X 5.0 kW	200-240	1	2+G	Hardwired	5.1	17.7-21.3	12.7 gal/48 liters
E215192	E215192M	2 X 3.0 kW	200-240	1	2+G	Hardwired	6.1	21.3-25.5	15.3 gal/58 liters
E215193	E215193M	2 X 2.3 kW	200-240	1	2+G	Hardwired	4.7-6.1	22.1-25.5	14.0 gal/53 liters

Configuration Codes		Heater Configuration	Voltage	Phase	Wires	Electrical Connection	KW	Maximum Amp Draw	Brew-Volume/Hour (1½ gallon per batch)
Plastic Brewbasket	Stainless Steel Brewbasket								
E215180	E215180M	1 X 5.0 kW	200-240	1	2+G	Hardwired	3.6	17.7	11.6 gal/44liters
E215181	E215181M	2 X 3.0 kW	200-240	1	2+G	Hardwired	4.3	21.3	14.3 gal/54 liters

Configuration Codes		Heater Configuration	Voltage	Phase	Wires	Electrical Connection	KW	Maximum Amp Draw	Brew-Volume/Hour (1½ gallon per batch)
Plastic Brewbasket	Stainless Steel Brewbasket								
(CE) E215161	(CE) E215161M	2 X 2.3 kW	230/400	2	2L,N,PE	Hardwired	5.6	12.4	14.0 gal/53 liters

Has CE and NSF-4 certification. Internal EMI filter. Not cUL and UL listed

CBS_2152XTS—Twin 1½ gallon version Electrical Configurations

Configuration Codes		Heater Configuration	Voltage	Phase	Wires	Electrical Connection	KW	Maximum Amp Draw	Brew-Volume/Hour (1½ gallon per batch)
Plastic Brewbasket	Stainless Steel Brewbasket								
E215251	E215251M	2 X 3.0 kW	208-240	1	2+G	Hardwired	4.6-6.1	22.4-25.8	15.3 gal/58 liters
Selectable—sold as 1 phase		3 X 3.0 kW	208-240	3	3+G	Hardwired	6.9-9.1	19.5-22.5	22.5 gal/85 liters
E215252	E215252M	2 X 5.0 kW	208-240	1	2+G	Hardwired	7.6-10.1	36.9-42.5	25.3 gal/97 liters
Selectable—sold as 1 phase		3 X 5.0 kW	208-240	3	3+G	Hardwired	11.4-15.1	32.0-36.9	38.3 gal/145 liters
E215253	E215253M	2 X 4.0 kW	208-240	1	2+G	Hardwired	6.1 - 8.1	29.3 - 33.8	19.8 gal/75 liters
Selectable—sold as 1 phase		3 X 4.0 kW	208-240	3	3+G	Hardwired	9.1-12.1	25.8 - 28.9	29.5 gal/112liters

Configuration Codes		Heater Configuration	Voltage	Phase	Wires	Electrical Connection	KW	Maximum Amp Draw	Brew-Volume/Hour (1½ gallon per batch)
Plastic Brewbasket	Stainless Steel Brewbasket								
E215292	E215292M	2 X 3.0 kW	208-240	1	2+G	Hardwired	4.6-6.1	22.4-25.8	15.3 gal/58 liters
E215293	E215293M	3 X 3.0 kW	208-240	3	4+G	Hardwired	6.9-9.1	19.5-22.5	22.5 gal/85 liters
E215294	E215294M	2 X 5.0 kW	208-240	1	2+G	Hardwired	7.6-10.1	36.9-42.5	25.3 gal/97 liters
E215295	E215295M	3 X 5.0 kW	208-240	3	4+G	Hardwired	11.4-15.1	32.0-36.9	38.3 gal/145 liters

Has UL & cUL and NSF-4 certification. Not certified CE

Configuration Codes		Heater Configuration	Voltage	Phase	Wires	Electrical Connection	KW	Maximum Amp Draw	Brew-Volume/Hour (1½ gallon per batch)
Plastic Brewbasket	Stainless Steel Brewbasket								
E215290	E215290M	3 X 3.0 kW	220/380 or 240/415	3	4+G	Hardwired	9.1	11.8-12.9	22.5 gal/85 liters
E215291	E215291M	3 X 5.0 kW	220/380 or 240/415	3	4+G	Hardwired	15.1	19.5-21.4	38.3 gal/145 liters

Has UL & cUL and NSF-4 certification. Not certified CE

Configuration Codes		Heater Configuration	Voltage	Phase	Wires	Electrical Connection	KW	Maximum Amp Draw	Brew-Volume/Hour (1½ gallon per batch)
Plastic Brewbasket	Stainless Steel Brewbasket								
E215280	E215280M	3 X 3.0 kW	200	3	3+G	Hardwired	6.5	18.6	17 gal/64 liters

Configuration Codes		Heater Configuration	Voltage	Phase	Wires	Electrical Connection	KW	Maximum Amp Draw	Brew-Volume/Hour (1½ gallon per batch)
Plastic Brewbasket	Stainless Steel Brewbasket								
(CE) E215261	(CE) E215261M	3 X 3.0 kW	230/400	3	3L,N,PE	Hardwired	8.6	12.4	22.5 gal/85 liters
(CE) E215262	(CE) E215262	3 X 5.0 kW	230/400	3	3L,N,PE	Hardwired	14.1	20.4	38.3 gal/145 liters

Has CE and NSF-4 certification. Internal EMI filter. Not cUL and UL listed

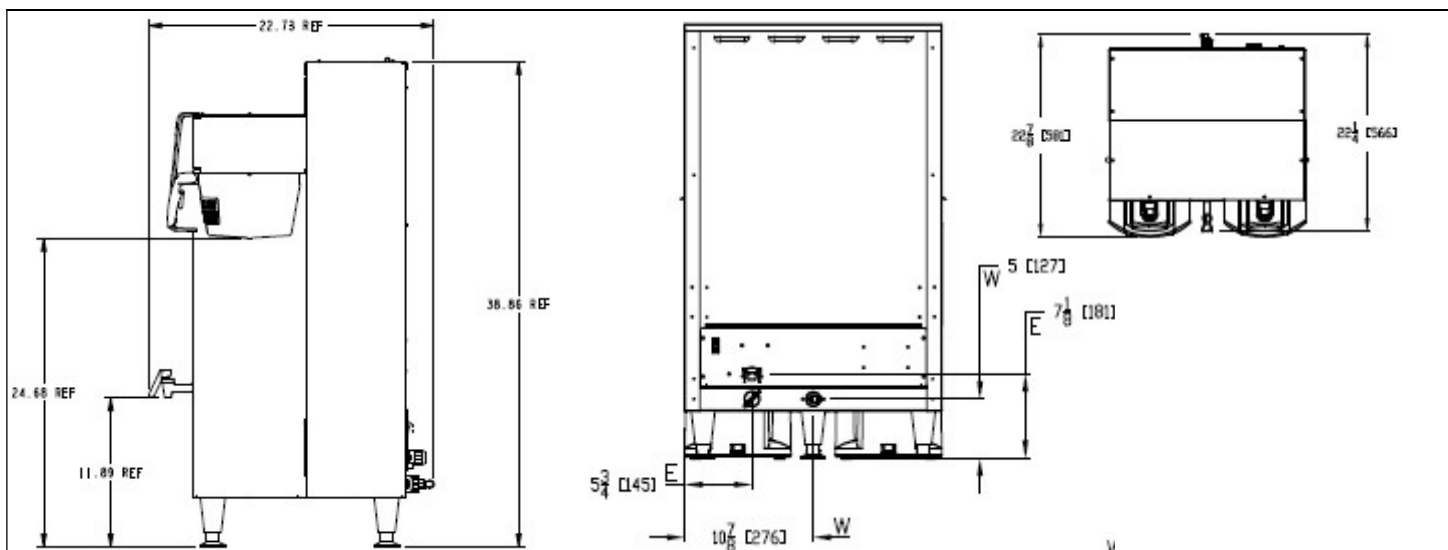

Rough-in CBS-2152-2 gallon XTS —Dual station version

NOTICE: This model uses 2 gallon dispensers

CBS-2150XTS Utility Requirements

- ❖ **Water Requirements:** 20-75 psig (138-517kPa) 1½gpm/(5.7lpm)
- ❖ **Inlet Water Temperature:** Cold supply
- ❖ **Coffee Filter Size:** →CBS-2150XTS: 15" X 5 ½ "
- ❖ **Cold Water Supply Only; Hardness >100 TDS (5.5 grain)**
- ❖ **Electrical:** See electrical configuration chart
- ❖ **Water inlet fitting** is a 3/8 inch male flare.
- ❖ .

CBS_2152-2 XTS—Twin 2 gallon version Electrical Configurations

Configuration Codes		Heater Configuration	Voltage	Phase	Wires	Electrical Connection	KW	Maximum Amp Draw	Brew-Volume/Hour (1½ gallon per batch)
Plastic Brewbasket	Stainless Steel Brewbasket								
E215351	E215351M	2 X 3.0 kW	208-240	1	2+G	Hardwired	4.6-6.1	22.4-25.8	15.3 gal/58 liters
Selectable—sold as 1 phase		3 X 3.0 kW	208-240	3	3+G	Hardwired	6.9-9.1	19.5-22.5	22.5 gal/85 liters
E215352	E215352M	2 X 5.0 kW	208-240	1	2+G	Hardwired	7.6-10.1	36.9-42.5	25.3 gal/97 liters
Selectable—sold as 1 phase		3 X 5.0 kW	208-240	3	3+G	Hardwired	11.4-15.1	32.0-36.9	38.3 gal/145 liters
E215353	E215233M	2 X 4.0 kW	208-240	1	2+G	Hardwired	6.1 - 8.1	29.3 - 33.8	19.8 gal/75 liters
Selectable—sold as 1 phase		3 X 4.0 kW	208-240	3	3+G	Hardwired	9.1-12.1	25.8 - 28.9	29.5 gal/112liters

Has UL & cUL and NSF-4 certification. Not certified CE

Configuration Codes		Heater Configuration	Voltage	Phase	Wires	Electrical Connection	KW	Maximum Amp Draw	Brew-Volume/Hour (1½ gallon per batch)
Plastic Brewbasket	Stainless Steel Brewbasket								
(CE) E215361	(CE) E215361M	3 X 3.0 kW	230/400	3	3L,N,PE	Hardwired	8.6	12.4	22.5 gal/85 liters
(CE) E215362	(CE) E215362M	3 X 5.0 kW	230/400	3	3L,N,PE	Hardwired	14.1	20.4	38.3 gal/145 liters

Has CE and NSF-4 certification. Internal EMI filter. Not cUL and UL listed

Final Setup for Startup

Final Setup

1. Turn on incoming water supply line and carefully inspect both inside and outside of the brewer for leaks in all fittings and tubes
2. Turn on power.
3. Press the brewer's main power switch (located on the lower right of the back of the equipment)

SCREENS SHOWN TO THE RIGHT WILL APPEAR

4. The water tank will begin filling. FETCO Home Screen #1 will read "FILLING".
5. When the water level rises and is sensed by the probe at the top of the tank the heaters will activate
6. Heaters are automatically disabled until the tank is full.

7. While the water is heating Screen #2 "HEATING" will display and the actual water temperature will be displayed.

8. After the water has reached the set temperature Screen #3 will display "READY"
9. Review the Operating Instructions. Brew one full batch (water only) on each side to confirm proper fill levels. The brewer is factory set with water only (no coffee) to dispense the correct amount of water. If the actual volume is slightly different from the programmed volume, fine tuning the brewer may be necessary. See Calibrate Valves in the OUTPUT section in the PROGRAMMING section.
10. Re-attach the covers after one final inspection for leaks. Look closely in the top of the brewer section at the dispense fittings during this inspection.

FETCO Home Screen #1





Home Screen #2 "HEATING"



FETCO Home Screen #3 "READY"

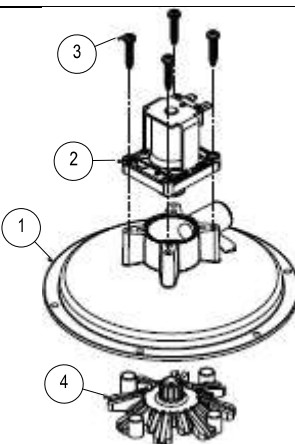

Parts and Wiring Diagrams

1102.00223.00 [Large] Spray Assembly Parts		CBS-2150XTS		
	Ref	QTY	PART NO	DESCRIPTION
	1	1	1102.00116.00	LARGESPRAY HOUSING ASSEMBLY
	2	1	1102.00222.00	VALVE, BREW, ASSEMBLY, 24 VDC
	3	4	1082.00056.00	SCREW, #8-11 X 1" THRD FORM, P/H PHIL
	4	1	1102.00043.00	CASCADE SPRAY DOME ASSY, CBS-2050'S
				Valve rebuild kit 1000.00108.00 DSV 11 24 volt DC Valve rebuild kit contains: Silicone diaphragm Pluger with spring

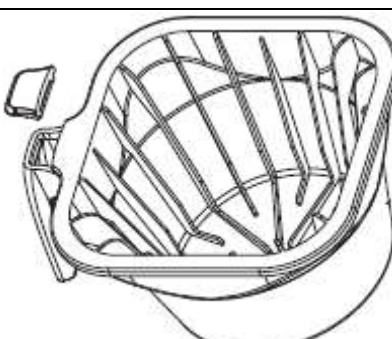
Brewbaskets															
Complete Brewbasket Part Number B015280BN2 CBS-2150XTS [ONLY]															
<p><i>Brown colored insert is standard</i></p> <p>→</p> <p>Brewbasket handle plug for polymeric brewbaskets is available in optional colors.</p>															
	<table border="1" style="width: 100%; border-collapse: collapse;"> <thead> <tr> <th style="text-align: left;">Part Number</th> <th style="text-align: left;">Plug Insert color</th> </tr> </thead> <tbody> <tr> <td>1023.00195.00</td> <td>BROWN PLUG, BB HANDLE</td> </tr> <tr> <td>1023.00194.00</td> <td>BLACK PLUG, BB HANDLE</td> </tr> <tr> <td>1023.00190.00</td> <td>RED PLUG, BB HANDLE</td> </tr> <tr> <td>1023.00191.00</td> <td>GREEN PLUG, BB HANDLE</td> </tr> <tr> <td>1023.00192.00</td> <td>ORANGE PLUG, BB HANDLE</td> </tr> <tr> <td>1023.00180.00</td> <td>BLUE PLUG, BB HANDLE</td> </tr> </tbody> </table>	Part Number	Plug Insert color	1023.00195.00	BROWN PLUG, BB HANDLE	1023.00194.00	BLACK PLUG, BB HANDLE	1023.00190.00	RED PLUG, BB HANDLE	1023.00191.00	GREEN PLUG, BB HANDLE	1023.00192.00	ORANGE PLUG, BB HANDLE	1023.00180.00	BLUE PLUG, BB HANDLE
Part Number	Plug Insert color														
1023.00195.00	BROWN PLUG, BB HANDLE														
1023.00194.00	BLACK PLUG, BB HANDLE														
1023.00190.00	RED PLUG, BB HANDLE														
1023.00191.00	GREEN PLUG, BB HANDLE														
1023.00192.00	ORANGE PLUG, BB HANDLE														
1023.00180.00	BLUE PLUG, BB HANDLE														

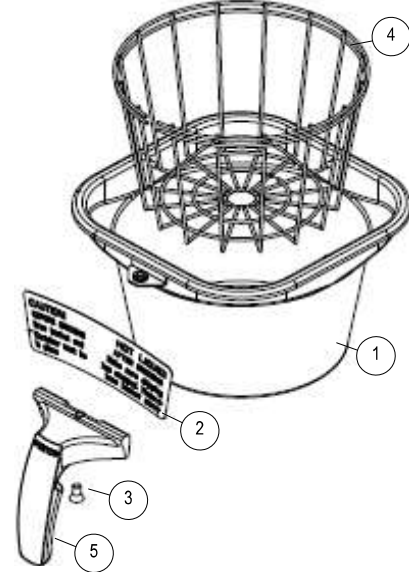
OPTIONAL Stainless Steel Brewbasket				
	Ref#	Qty	Part Number	Description
	←		B001280B1	Complete Stainless Steel Brewbasket
	1	1	1112.00058.00	BB WLDMNT
	2	1	1046.00025.00	BREW BASKET WARNING LABEL
	3	1	1082.00040.00	SCREW, 1/4-20 X .5, FL HD, PH., W/NYLN
	4	1	1009.00005.00	WIRE BASKET
	5	1	1102.00064.00	HANDLE W/MAGNET ASY, BLACK
	Optional colored handle		1102.00065.00	HANDLE W/MAGNET ASY, RED
Optional colored handle		1102.00066.00	HANDLE W/MAGNET ASY, GREEN	
Optional colored handle		1102.00067.00	HANDLE W/MAGNET ASY, ORANGE	

PROPRIETARY AND CONFIDENTIAL. THE INFORMATION CONTAINED IN THIS DRAWING IS THE SOLE PROPERTY OF FETCO. ANY REPRODUCTION IN PART OR AS A WHOLE WITHOUT THE WRITTEN PERMISSION OF FETCO IS PROHIBITED.

REVISIONS				BY:	A
REV	DATE	ECO NO	DESCRIPTION		
A	08/15/2014	N/A	ORIGINAL		AG

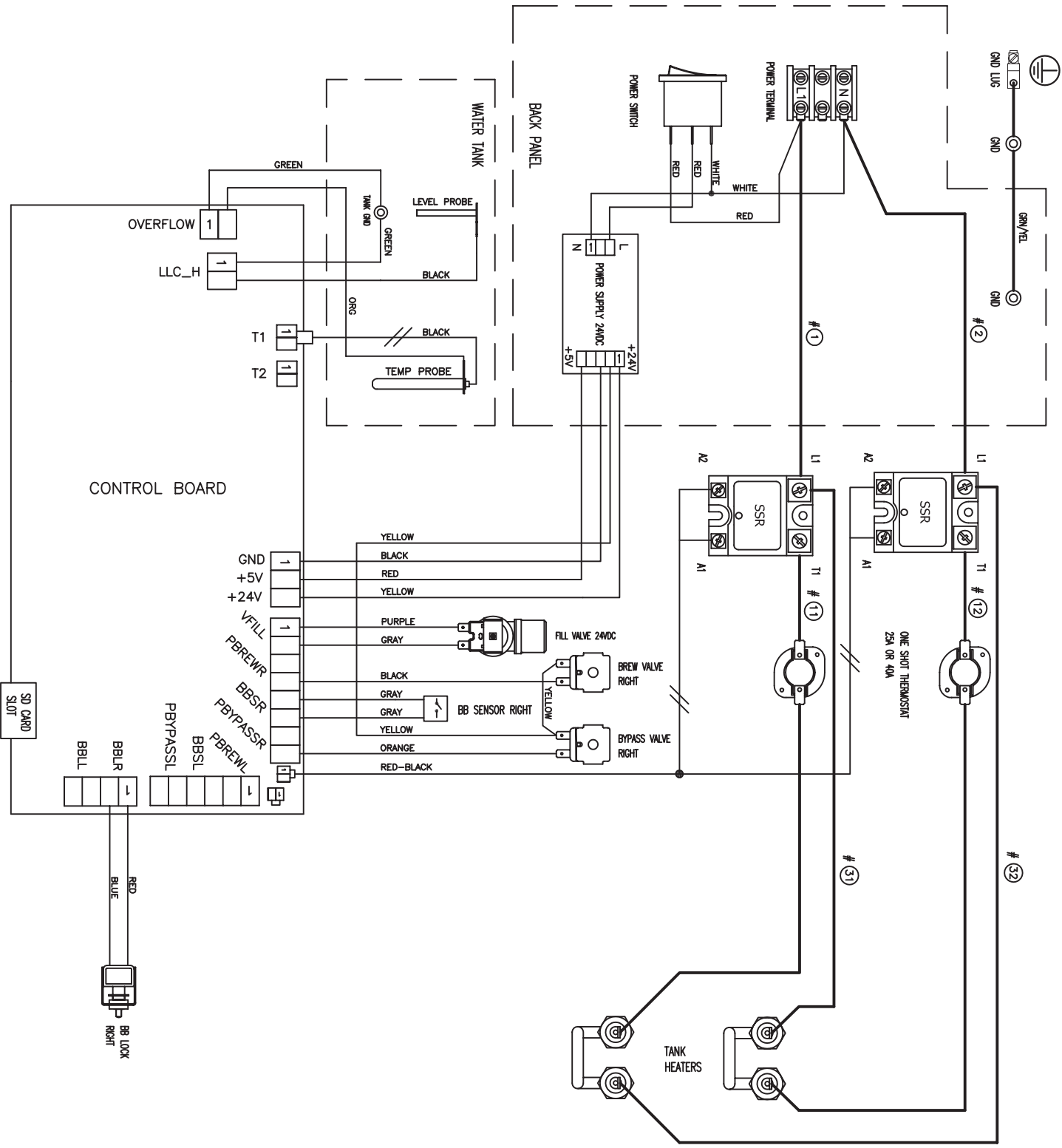

TOLERANCES	REVISIONS			FETCO®	FOOD EQUIPMENT TECHNOLOGY COMPANY		
	NO.	DATE	BY		600 ROSE RD. LAKE ZURICH, IL 60047 PHONE: 847-719-3000, FAX: 847-719-3001 WWW.FETCO.COM		
EXCEPT AS NOTED	A	08/15/2014	AG	DWG. NAME: WIRING, CBS-2151-XTS, L1, N+GND, 2 HEATERS, EXPORT DRAWN BY: AG SCALE: N/A CHK'D: SZ SIZE: A APP'D: LW DATE: 08-15-2014	MATERIAL: N/A DRAWING NO.: 1401.00100.00		
DECIMAL	B						
FRACTIONAL	C						
ANGULAR	D						
	E						

REVISIONS			
REV	DATE	ECO NO	DESCRIPTION
A	08/12/2014	N/A	ORIGINAL

BY: A
AG

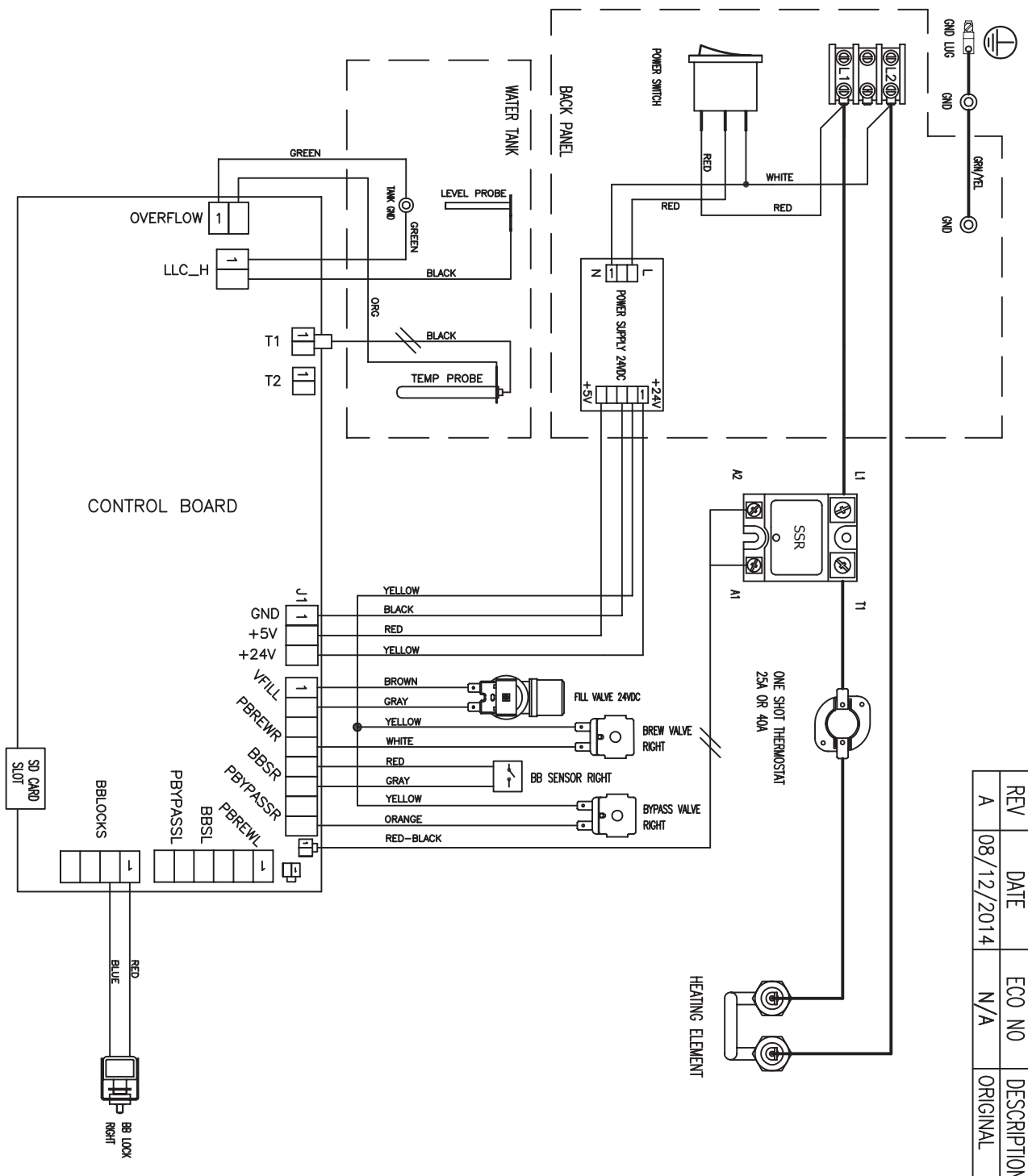

PROPRIETARY AND CONFIDENTIAL.
THE INFORMATION CONTAINED IN THIS DRAWING IS THE SOLE PROPERTY OF FETCO. ANY REPRODUCTION IN PART OR AS A WHOLE WITHOUT THE WRITTEN PERMISSION OF FETCO IS PROHIBITED.

TOLERANCES		REVISIONS	
EXCEPT AS NOTED	NO.	DATE	BY
DECIMAL	A	08/12/2014	AG
FRACTIONAL	B		
ANGULAR	C		
	D		
	E		

FETCO
 DWG. NAME: WIRING, CBS-2141/51-XTS, L1, L2+GND,
 1 HEATER, JAPAN
 DRAWN BY: AG
 CHK'D: SZ
 APP'D: LW
 DATE: 08-12-2014

FOOD EQUIPMENT TECHNOLOGY COMPANY
 600 ROSE RD.
 LAKE ZURICH, IL 60047
 WWW.FETCO.COM
 847-719-3001 FAX: 847-719-3011

MATERIAL: N/A
 DRAWING NO.: 1401.00096.00

NOTICE TO LICENSED INSTALLER

SINGLE PHASE
 JUMP L2 & L3
 POWER L1 & L2

THREE PHASE
 NO JUMPER!
 POWER L1, L2, & L3

REVISIONS				
REV	DATE	ECO NO	DESCRIPTION	BY:
A	02/14/2014	N/A	ORIGINAL	AG
B	05/22/2014	N/A	4000W/240VAC HEATER ADDED	AG

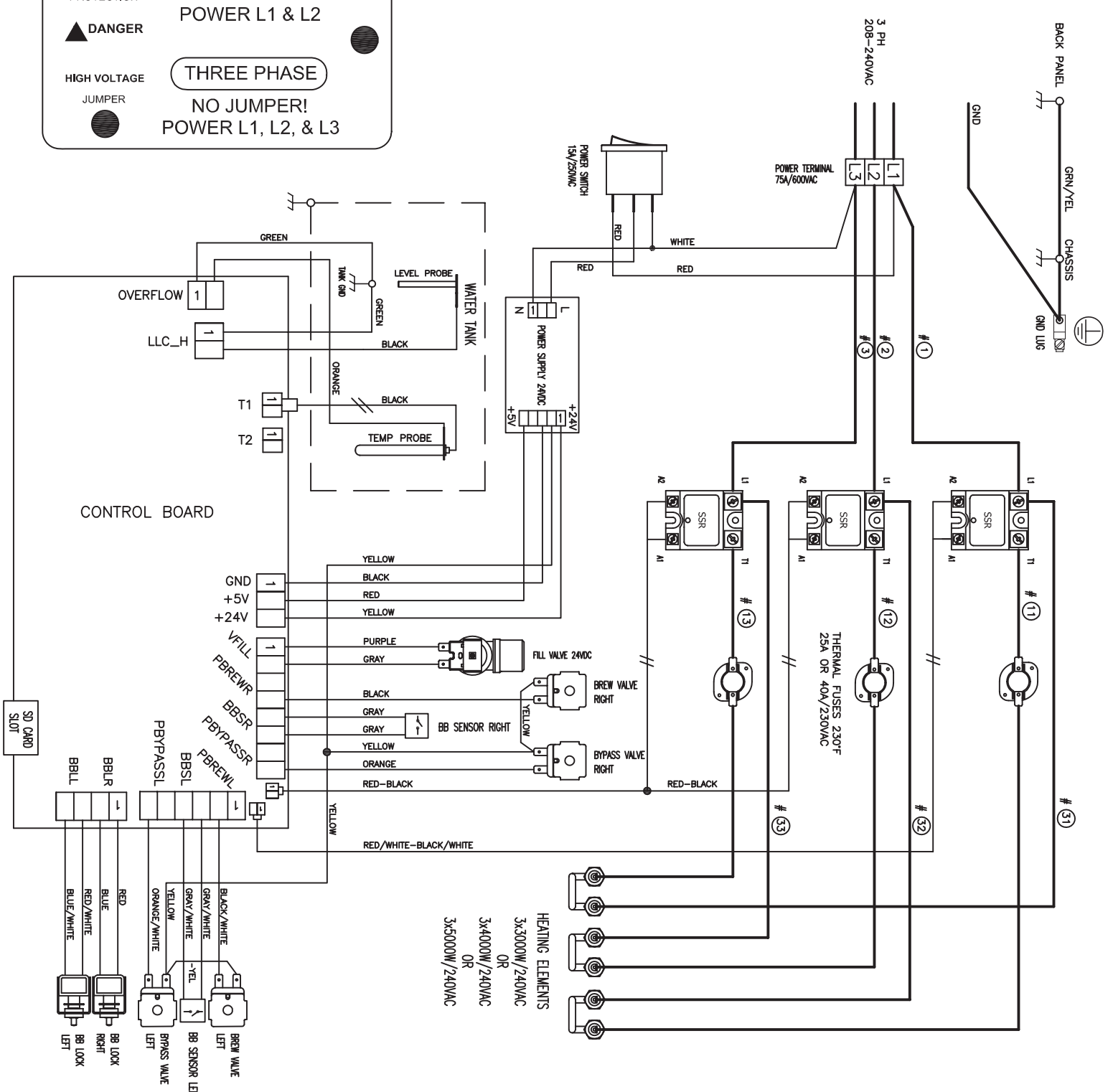

CBS-2152 XTS

HEATER CONFIG.	VOLTAGE	PH	WIRES	KW	MAX AMP DRAW
2x3000W	208-240	1	2+G	4.6-6.1	22.4-25.8
3x3000W	208-240	3	3+G	7.0-9.1	19.4-22.4
2x4000W	208-240	1	2+G	6.1-8.1	29.3-33.8
3x4000W	208-240	3	3+G	9.2-12.1	25.6-29.6
2x5000W	208-240	1	2+G	7.6-10.1	36.5-42.1
3x5000W	208-240	3	3+G	11.5-15.1	32.0-36.9

TOLERANCES		REVISIONS				<small>FOOD EQUIPMENT TECHNOLOGY COMPANY 600 ROSE RD. LAKE ZURICH, IL 60047 PHONE: 847-719-3000, FAX: 847-719-3001 WWW.FETCO.COM</small>		
EXCEPT AS NOTED	DECIMAL	NO.	DATE	BY		DWG. NAME:	SCALE	MATERIAL
	+/- .005	A	02-14-14	AG	WIRING UL, CBS-2152 XTS, L1, L2, L3+GND, 3 HEATERS	N/A	N/A	
	FRACTIONAL	B	05-22-14	AG				
	+/- 1/64"	C						
	ANGULAR	D						
	+/- 1/2 DEG	E						
						DRAWN BY AG CHK'D LW APP'D LW	DATE 02-14-2014	DRAWING NO. 1401.00086.00

REVISIONS					A
REV	DATE	ECO NO	DESCRIPTION	BY:	
A	12/11/2013	N/A	ORIGINAL	AG	

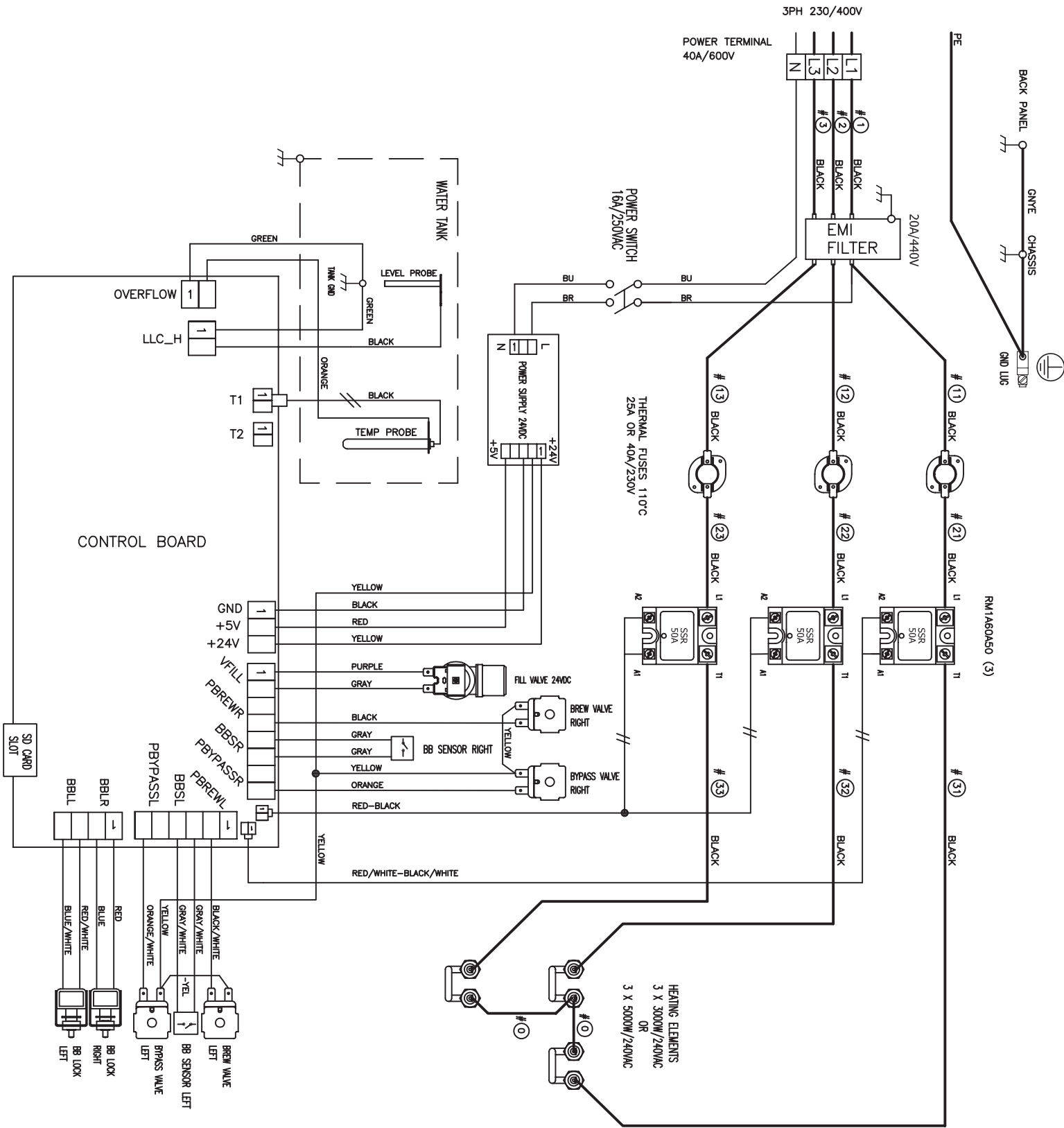

CBS-2152 XTS

HEATER CONFIGURATION	VOLTAGE	PH	WIRES	KW	MAX AMP DRAW
3x3.0kW/240V	230/400	3	3L, N, PE	8.6	12.4
3x5.0kW/240V	230/400	3	3L, N, PE	14.1	20.4

TOLERANCES		REVISIONS			FETCO®	FOOD EQUIPMENT TECHNOLOGY COMPANY 600 ROSE RD. LAKE ZURICH, IL 60047 PHONE: 847-719-3000, FAX: 847-719-3001 WWW.FETCO.COM					
EXCEPT AS NOTED	DECIMAL	NO.	DATE	BY		DWG. NAME:	SCALE	MATERIAL			
	+/- .005	A	12-11-13	AG	WIRING, CBS-2152 XTS, 3PH, CE	N/A	N/A				
	FRACTIONAL	B									
	+/- 1/64"	C									
	ANGULAR	D									
	+/- 1/2 DEG	E									
						DRAWN BY	AG	SIZE	A	DRAWING NO.	1401.00080.00
						CHK'D	LW	DATE	12-11-2013		
						APP'D	LW				

REVISIONS					A
REV	DATE	ECO NO	DESCRIPTION	BY:	
A	12/10/2013	N/A	ORIGINAL	AG	

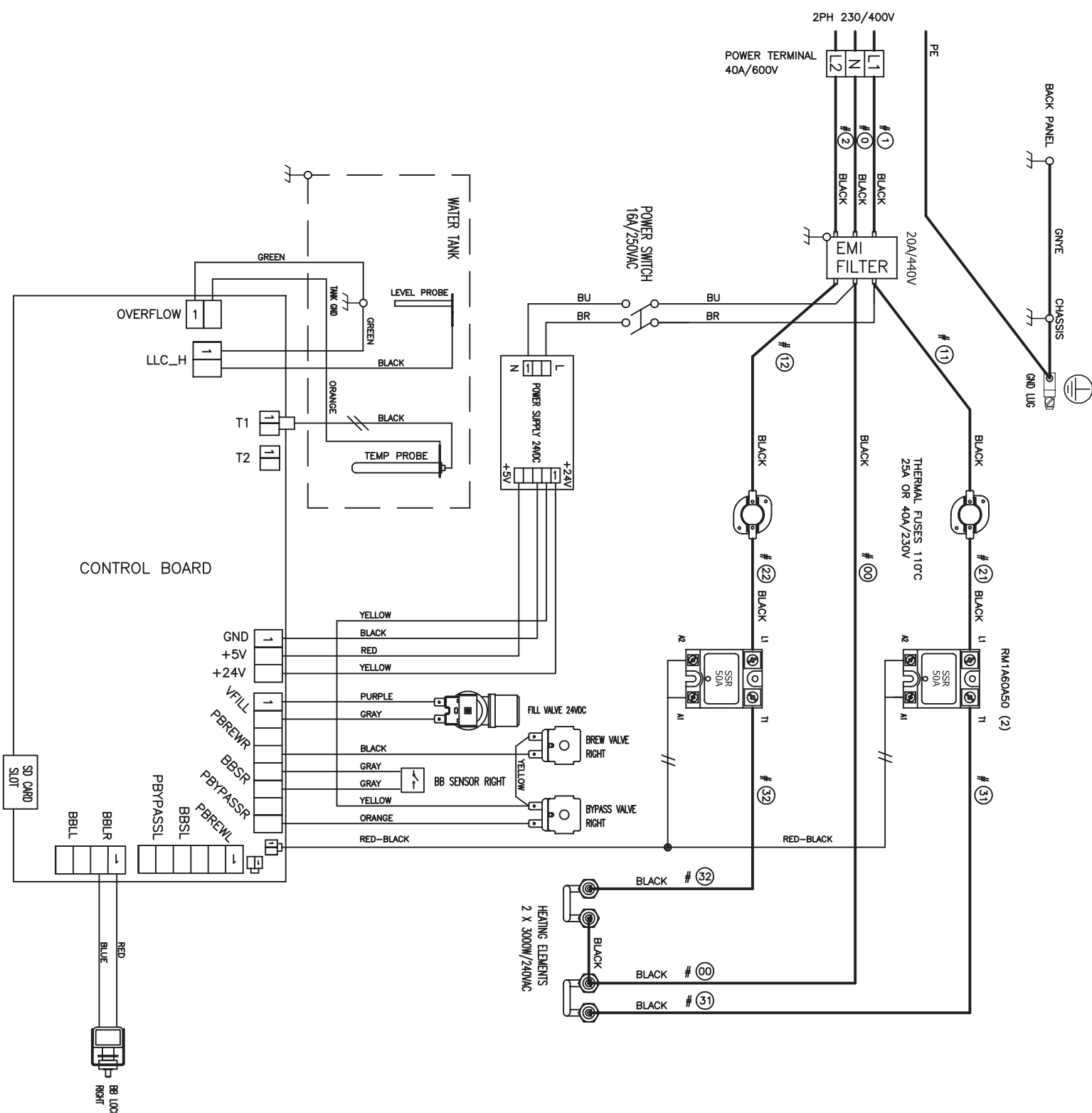

CBS-2151 XTS

HEATER CONFIGURATION	VOLTAGE	PH	WIRES	KW	MAX AMP DRAW
2x3.0kW/240V	230/400	2	2L, N, PE	5.6	12.4

TOLERANCES	REVISIONS			FETCO®	FLOOD EQUIPMENT TECHNOLOGY COMPANY 800 ROSE RD. LAKE ZURICH, IL 60047 PHONE: 847-719-3000, FAX: 847-719-3001 WWW.FETCO.COM		
	EXCEPT AS NOTED	NO.	DATE		BY	DWG. NAME:	SCALE
DECIMAL	A	12-10-13	AG		WIRING, CBS-2151 XTS, 2PH, CE	N/A	N/A
FRACTIONAL	B				DRAWN BY AG	SCALE N/A	MATERIAL N/A
ANGULAR	C				CHK'D LW	SIZE A	DRAWING NO.
	D				APP'D LW	DATE 12-10-2013	1401.00076.00

REVISIONS				BY:	A
REV	DATE	ECO NO	DESCRIPTION		
A	12/22/2014	N/A	ORIGINAL	SZ	

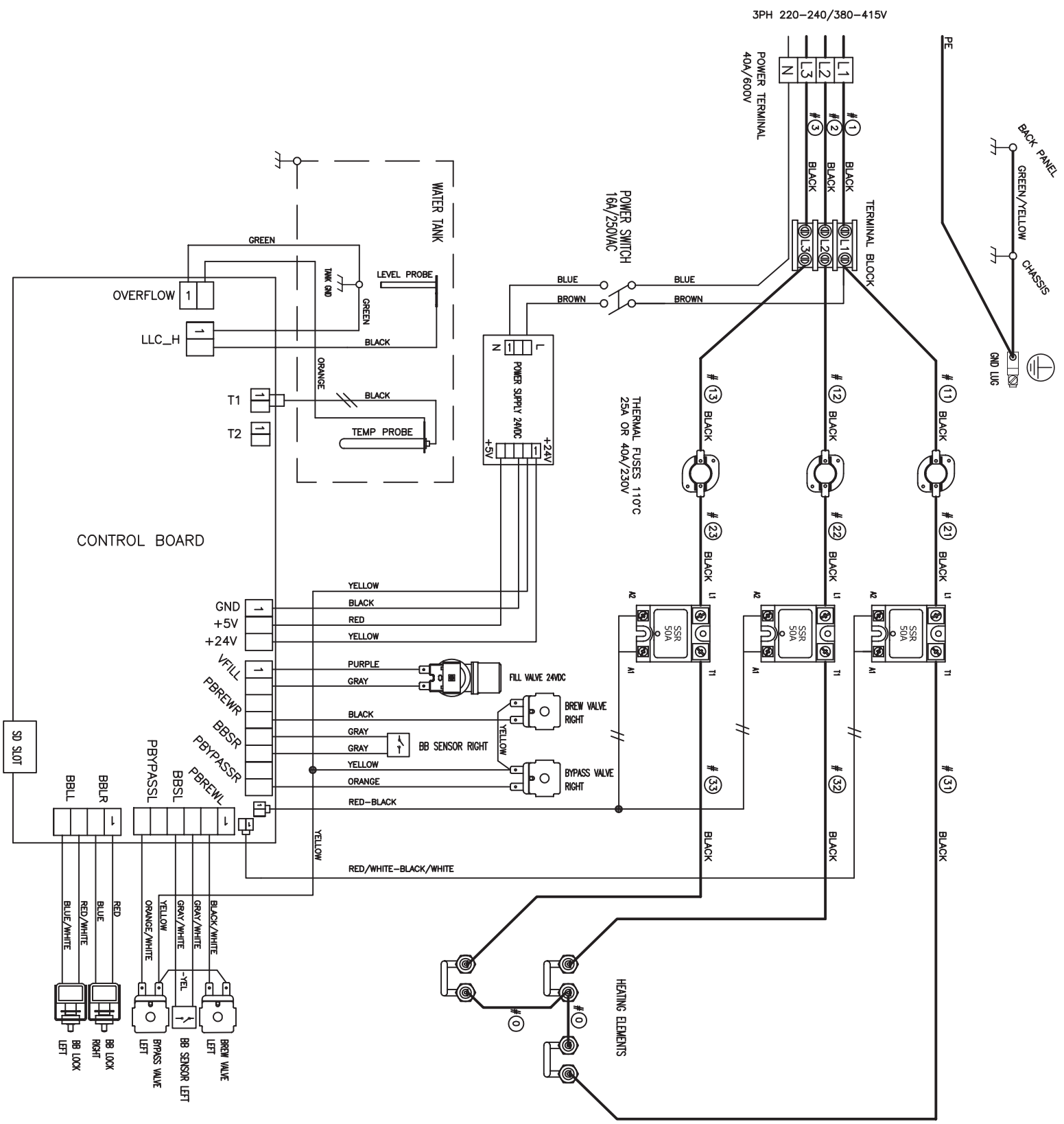

TOLERANCES	REVISIONS			FETCO®	FOOD EQUIPMENT TECHNOLOGY COMPANY		
	NO.	DATE	BY		600 ROSE RD.	LAKE ZURICH, IL 60047	PHONE: 847-719-3000, FAX: 847-719-3001
EXCEPT AS NOTED	A	12-22-14	SZ	DWG. NAME: WIRING, CBS-2152-XTS, L1, L2, L3, N+GND, 3 HEATERS, EXPORT			
DECIMAL +/- .005	B			DRAWN BY	SCALE	N/A	MATERIAL
FRACTIONAL +/- 1/64"	C			SZ			N/A
ANGULAR +/- 1/2 DEG	D			CHK'D	AG	SIZE	A
	E			APP'D	LW	DATE	12-22-2014
							DRAWING NO. 1401.00112.00

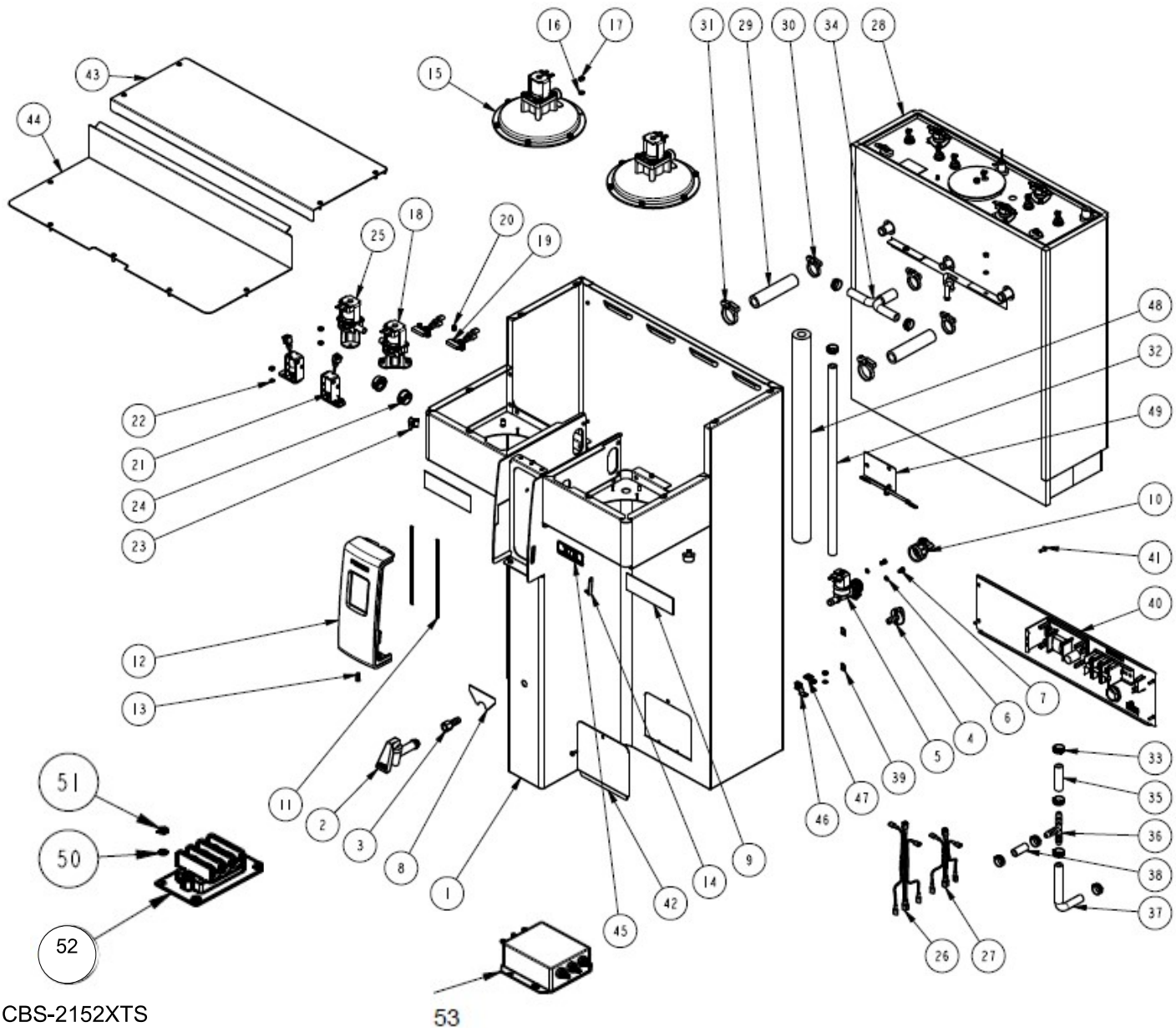

CBS-2152XTS

		Bill of Materials	CBS-2152XTS
Ref	#	Part Number	Name
1	1	1111.00046.00	WELDMENT BODY COMPLETE, CBS-2152 XTS
1	1	1111.00052.00	WELDMENT BODY COMPLETE, CBS-2152 XTS, 2 GAL
2	1	1071.00010.00	FAUCET HPSC-BR-8 REGULAR HANDLE
3	1	1031.00003.00	FITTING, BARB 3/8"ID x 1/4" FPT
4	1	1023.00147.00	PLUG, TANK SERVICE DRAIN FOR 18GA AND UP BODY
5	1	1057.00043.00	SOLENOID VALVE, SINGLE, 180 DEG, 240VDC
6	2	1083.00005.00	WASHER, M4 18-8 INTERNAL TOOTH LOCKWASHER
7	2	1082.00010.00	SCREW, M4x10 ZINC PLATED PAN PHILLIPS MACHINE
8	1	1046.00006.00	LABEL, WARNING, "HOT WATER FAUCET"
9	2	1046.00003.00	LABEL, CSD WARNING, 1.5" X 5.0"
10	1	1102.00243.00	ADAPTER ASSY, 3/4" BSP x 1/4" NPT x 3/8" TUBE
11	2	1024.00049.00	EDGE PROTECTOR, 7.00"LG, CBS-2130
12	1	1102.00210.00	ASSEMBLY, FRONT PANEL, CBS-2100 XTS
13	4	1082.00058.00	SCREW, # 8-32 X 5/8, FLAT HD, PH, 18-8 SS
14	1	1024.00040.00	CARD PLUG, HWD-2100
15	2	1102.00223.00	SPRAY HOUSING, LARGE, COMPLETE ASSEMBLY, 24 VDC
16	16	1083.00010.00	WASHER, #10 SCREW W/NEOPRENE-BONDED SEAL
17	24	1084.00006.00	NUT, 8-32 18-8 HEX MACHINE SCREW
18	1	1102.00220.00	ASSEMBLY, BYPASS VALVE, RIGHT
19	2	1102.00113.00	SWITCH, REED, ASSEMBLY
20	4	1029.00006.00	#4-40 NYLON FINGER NUT
21	2	1102.00219.00	ASSEMBLY, BB LOCKER, 24VDC
22	8	1083.00011.00	WASHER, #8 SCREW SIZE, INTERNAL TOOTH LOCK
23	2	1023.00159.00	CORNER INSERT
24	2	1086.00004.00	BUSHING, SNAP, 1" MOUNTING HOLE
25	1	1102.00221.00	ASSEMBLY, BYPASS VALVE, LEFT
26	1	1402.00051.00	HARNESS LOW AMP, CBS-2142/52 XTS, CE/UL
27	1	1402.00053.00	HARNESS HIGH AMP, CBS-2152 XTS, UL
28	1	1104.00080.00	TANK ASSY, 2 X 3.0kW/240VAC , CBS-2152 XTS
28	1	1104.00081.00	TANK ASSY, 2 X 5.0kW/240VAC , CBS-2152 XTS
28	1	1104.00062.00	TANK ASSY, 3 X 3.0kW/240VAC , CBS-2152 XTS
28	1	1104.00075.00	TANK ASSY, 3 X 4.0kW/240VAC , CBS-2152 XTS
28	1	1104.00074.00	TANK ASSY, 3 X 5.0kW/240VAC , CBS-2152 XTS
29	2	1025.00021.00	TUBE, 31/32"OD X 5/8"ID X 4 1/4"LG, BREW
30	3	1086.00018.00	HEYCO HOSE CLAMP DIA. .875-1.00
31	2	1086.00017.00	HEYCO HOSE CLAMP DIA .1.031-1.187
32	1	1025.00082.00	TUBE, 5/8"OD X 3/8"ID X 19.00"LG, BY-PASS
33	9	1086.00003.00	UNICLAMP, 15.9 HOSE OD CLAMP
34	1	1024.00064.00	BY-PASS MANIFOLD, SILICONE, CBS-2142/52
35	1	1025.00060.00	TUBE 9/16"OD X 5/16"ID X 3.25"LG
36	1	1029.00002.00	FITTING, HOSE BARB TEE, SIZE 3/8" , NYLON
37	1	1025.00077.00.	TUBE, 9/16 OD x 5/16 ID x 6.50 LG
38	1	1025.00058.00	TUBE, 9/16"OD X 5/16"ID X 25.00"LG
39	12	1084.00011.00	NUT, CLIP ON (J-NUT), #6-32, 22-20 GA., BLK-PH FINISH
40	1	1102.00229.00	ASSEMBLY BACK PANEL, 3 TERM. BLK, CBS-2152 XTS
40	1	1102.00217.00	ASSEMBLY, BACK PANEL, CBS-2152 CE Version
41	15	1082.00017.00	SCREW, # 6-32 X 1/2" TRUSS HD PHIL., MACHINE
42	2	1001.00181.00	COVER FRONT, CBS-2100 XTS
43	1	1001.00182.00	COVER, TOP CBS-2152 XTS
44	1	1001.00183.00	COVER, UPPER BASE, CBS-2152 XTS
45	1	1041.00013.00	LABEL, XTS, 2130,2140 AND 2150 SERIES
46	1	1065.00002.00	CONNECTOR, COPPER LUG
47	1	1044.00012.00	LABEL GROUND CE
48	1	1022.00072.00	INSULATION, 5/8"ID X 3/8"TH, 18.5"LG
49	1	1102.00239.00	CARD ASSY, SINGLE OR THREE PHASE JUMPER
50	1	1102.00284.00	ASSEMBLY TERMINAL, BRACKET
51	4	1083.00009.00	WASHER, #6 SCREW , INTL TOOTH LOCKWASHER
52	4	1084.00012.00	NUT, HEX, #6-32 MACHINE SCREW
53	1	1052.00027.00	EMI FILTER, THREE LINE 30A, 250/440VAC
	2	B001280B1	Stainless Steel Brewbasket
	2	B015280BN2	BB ASSEMBLY, 16" x 6", Ø.280" HOLE

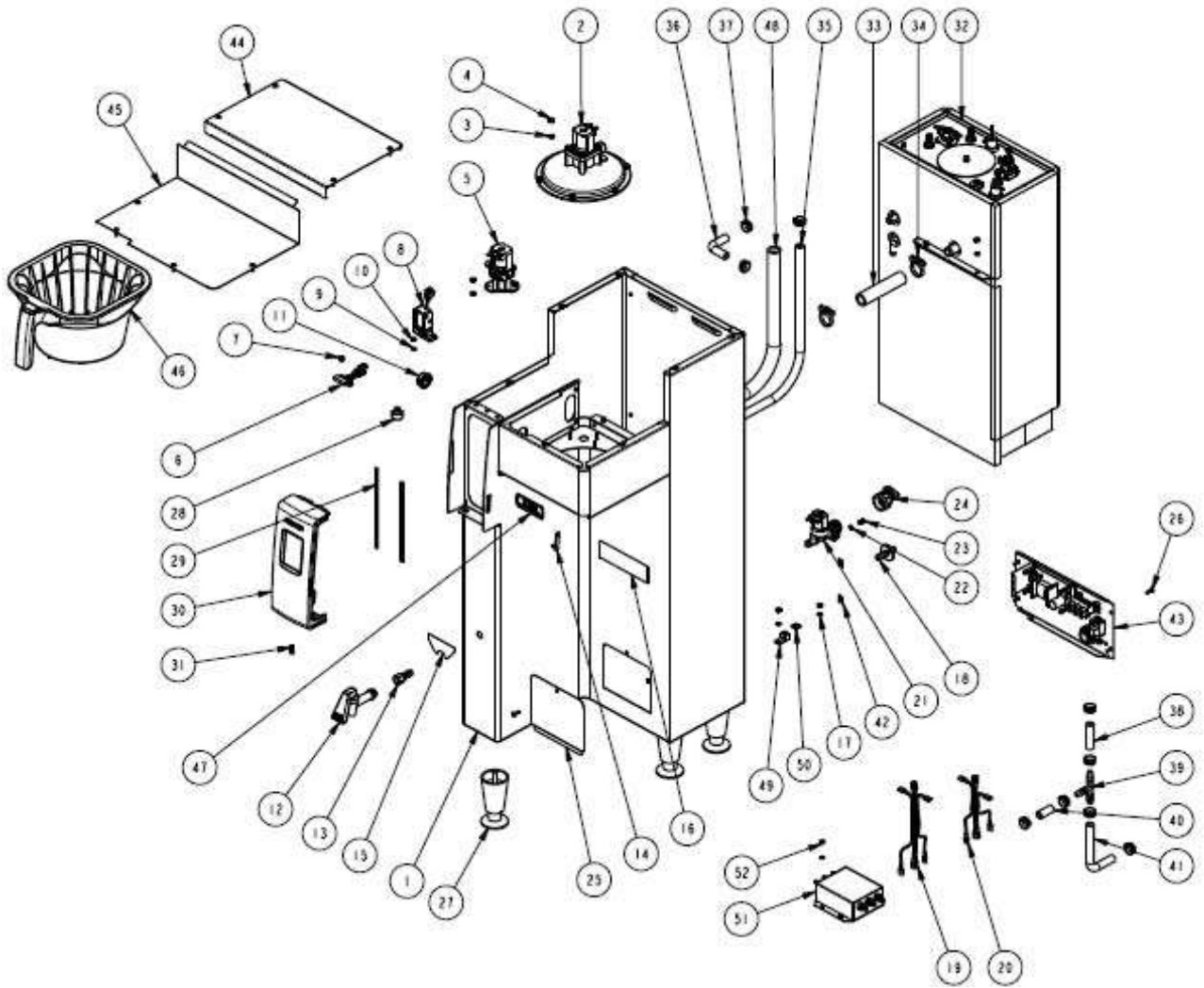

Drawing 1101.00214.00 CBS-2151XTS

Drawing 1101.00214.00 CBS-2151XTS CE Version			
Ref	#	Part Number	Name
1	1	1111.00047.00	WELDMT BODY COMPLETE, CBS-2151 XTS
2	1	1102.00223.00	SPRAY HOUSING, LARGE, COMPLETE ASSEMBLY, 24 VDC
3	8	1083.00010.00	WASHER, #10 SCREW W/NEOPRENE-BONDED SEAL
4	12	1084.00006.00	NUT, 8-32 18-8 HEX MACHINE SCREW
5	1	1102.00220.00	ASSEMBLY, BYPASS VALVE, RIGHT
6	1	1102.00113.00	SWITCH, REED, ASSEMBLY
7	2	1029.00006.00	#4-40 NYLON FINGER NUT
8	1	1102.00219.00	ASSEMBLY, BB LOCKER, 24VDC
9	6	1083.00009.00	WASHER, #6 SCREW , INTL TOOTH LOCKWASHER
10	2	1084.00010.00	NUT, HEX, #6-32, UNDERSIZED, ZINC PLATED
11	1	1086.00004.00	BUSHING, SNAP, 1" MOUNTING HOLE
12	1	1071.00010.00	FAUCET HPSC-BR-8 REGULAR HANDLE
13	1	1031.00003.00	FITTING, BARB 3/8"ID x 1/4" FPT
14	1	1024.00040.00	CARD PLUG, HWD-2100
15	1	1046.00006.00	LABEL, WARNING, "HOT WATER FAUCET"
16	1	1046.00003.00	LABEL, CSD WARNING, 1.5" X 5.0"
17	4	1083.00011.00	WASHER, #8 SCREW SIZE, INTERNAL TOOTH LOCK
18	1	1023.00147.00	PLUG, TANK SERVICE DRAIN FOR 18GA AND UP BODY
19	1	1402.00045.00	HARNESS LOW AMP, CBS-2141/51 XTS, CE/UL
20	1	1402.00050.00	HARNESS HIGH AMP, CBS-2151 XTS, CE
21	1	1057.00043.00	SOLENOID VALVE, SINGLE, 180 DEG, 24VDC
22	2	1083.00005.00	WASHER, M4 18-8 INTERNAL TOOTH LOCKWASHER
23	2	1082.00010.00	SCREW, M4x10 ZINC PLATED PAN PHILLIPS MACHINE
24	1	1102.00243.00	ADAPTER ASSY, 3/4" BSP x 1/4" NPT x 3/8" TUBE
25	1	1001.00181.00	COVER FRONT, CBS-2100 XTS
26	13	1082.00017.00	SCREW, # 6-32 X 1/2" TRUSS HD PHIL., MACHINE
27	4	1073.00007.00	LEG, FLANGE FOOT, 4" HIGH
28	1	1023.00159.00	CORNER INSERT
29	2	1024.00049.00	EDGE PROTECTOR, 7.00"LG, CBS-2130
30	1	1102.00210.00	ASSEMBLY FRONT PANEL, CBS-2130, GRAVITY VERSION
31	4	1082.00058.00	SCREW, # 8-32 X 5/8, FLAT HD, PH, 18-8 SS
32	1	1104.00096.00	TANK ASSY, 2 X 2.3kW/240V, CBS-2151 XTS
32	1	1104.00061.00	TANK ASSY, 2 X 3.0kW/240V, CBS-2151 XTS
32	1	1104.00097.00	TANK ASSY, 2 X 4.0kW/240V, CBS-2151 XTS
32	1	1104.00095.00	TANK ASSY, 2 X 5.0kW/240V, CBS-2151 XTS
33	1	1025.00021.00	TUBE, 31/32"OD X 5/8"ID X 4 1/4"LG, BREW
34	2	1086.00018.00	CLAMP, HOSE, .875"-1.0" DIA RANGE
35	1	1025.00083.00	TUBE, 5/8 OD x 3/8 ID x 18.0" LG.
36	1	1025.00061.00	TUBE, 9/16"OD X 5/16"ID X 2.75"LG
37	9	1086.00003.00	UNICLAMP, 15.9 HOSE OD CLAMP
38	1	1025.00060.00	TUBE, 9/16"OD X 5/16"ID X 3.25"LG
39	1	1029.00002.00	FITTING, HOSE BARB TEE, SIZE 3/8" , NYLON
40	1	1025.00058.00	TUBE, 9/16"OD X 5/16"ID X 25.00"LG
41	1	1025.00077.00	TUBE, 9/16 OD x 5/16 ID x 6.50 LG.
42	11	1084.00011.00	NUT, CLIP ON (J-NUT), #6-32, 22-20 GA., BLK-PH FINISH
43	1	1102.00231.00	ASSEMBLY, BACK PANEL, CBS-2151
43	1	1102.00216.00	ASSEMBLY, BACK PANEL, CBS-2151 CE
44	1	1001.00190.00	COVER TOP, CBS-2151 XTS
45	1	1001.00189.00	COVER, UPPER BASE, CBS-2151 XTS
46	1	B015280BN2	BB ASSEMBLY, 16" x 6", Ø.280" HOLE
47	1	1041.00013.00	LABEL, XTS, 2130,2140 AND 2150 SERIES
48	1	1022.00073.00	INSULATION, 5/8 ID x 3/8 THK. x 17.5" LG.
49	1	1065.00009.00	GROUND LUG CONNECTOR, 14-2 AWG, ALUMINUM
50	1	1044.00012.00	LABEL GROUND CE
51	1	1052.00036.00	EMI FILTER, PE360M-20, THREE LINE 20A, 250/440VAC
52	4	1084.00012.00	NUT, HEX, #6-32 MACHINE SCREW, 18-8 SS
	1	B001280B1	Stainless Steel Brewbasket
	1	B015280BN2	BB ASSEMBLY, 16" x 6", Ø.280" HOLE

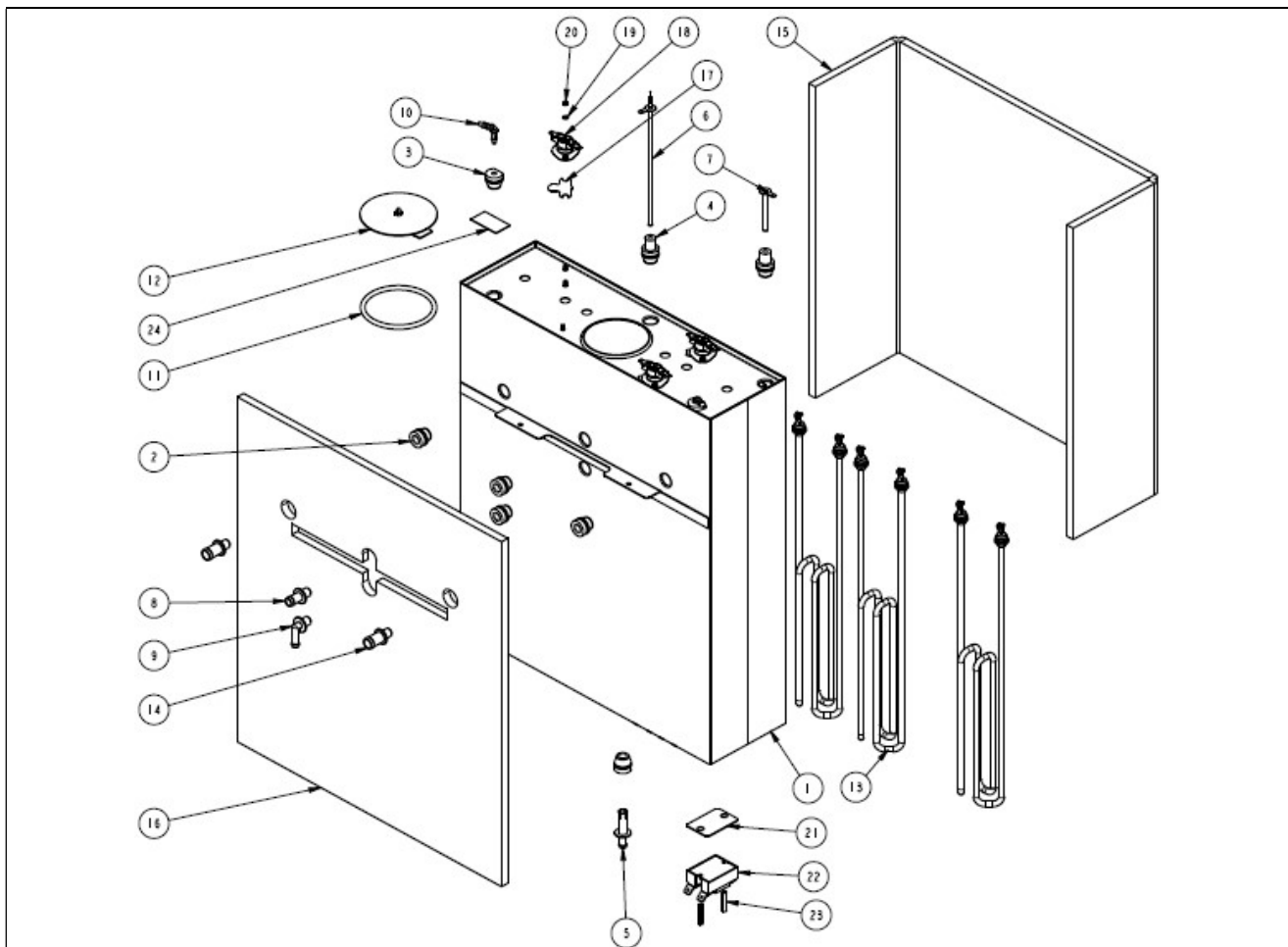

TANK ASSY CBS-2152 XTS			
Ref	#	Part Number	Name
1	1	1114.00091.00	WELDMENT, TANK CBS-2152
2	5	1024.00050.00	GROMMET, SILICONE, 11.4mm ID
3	2	1024.00062.00	GROMMET, SHORT, SILICONE, LEVEL AND TEMP PROBE
4	2	1024.00053.00	LEVEL AND TEMP PROBE GROMMET
5	1	1023.00166.00	FITTING, COLD WATER INLET, GROMMET DESIGN
6	1	1102.00161.00	PROBE ASSEMBLY, TEMP. AND LLC, HWD-2100
7	1	1112.00019.00	PROBE WELDMENT, WATER LEVEL 2.600" LG
8	1	1023.00167.00	FITTING, BREW, GROMMET DESIGN
9	1	1023.00183.00	FITTING, DILUTION, TBS-2121
10	2	1029.00023.00	FITTING, SINGLE BARBED ELBOW, 1/4", KYNAR
11	1	1024.00007.00	O-RING, DASH #344, TANK COVER
12	1	1102.00007.00	TANK COVER ASSEMBLY
13		1107.00005.00	HEATER ASSEMBLY, IMMERSION 3000W/240VAC
13		1107.00010.00	HEATER ASSEMBLY, IMMERSION 4000W/240VAC
13		1107.00032.00	HEATER ASSEMBLY, IMMERSION 5000W/240VAC
14	2	1023.00203.00	FITTING, BREW, GROMMET DESIGN
15	1	1022.00071.00	INSULATION, TANK BACK, CBS-2152
16	1	1022.00070.00	INSULATION, TANK FRONT, CBS-2152
17	3	1003.00005.00	BRACKET, ONE SHOT THERMOSTAT
18	3	1053.00003.00	THERMOSTAT, SINGLE SHOT, 240V/40A
19	7	1083.00009.00	WASHER, #6 SCREW , INTL TOOTH LOCKWASHER
20	6	1084.00010.00	NUT, HEX, #6-32, UNDERSIZED, ZINC PLATED
21	3	1003.00140.00	ALUMINUM BRACKET FOR SSR
22	3	1052.00033.00	RELAY, SOLID STATE, 50A/600VAC, W/BUILD IN VARISTOR
23	6	1081.00042.00	STANDOFF, 1/4" HEX
24		1044.00004.00	LABEL, WARNING-HIGH VOLTAGE
	6	1065.00006.00	CONNECTOR, TAB, .250", FASTON

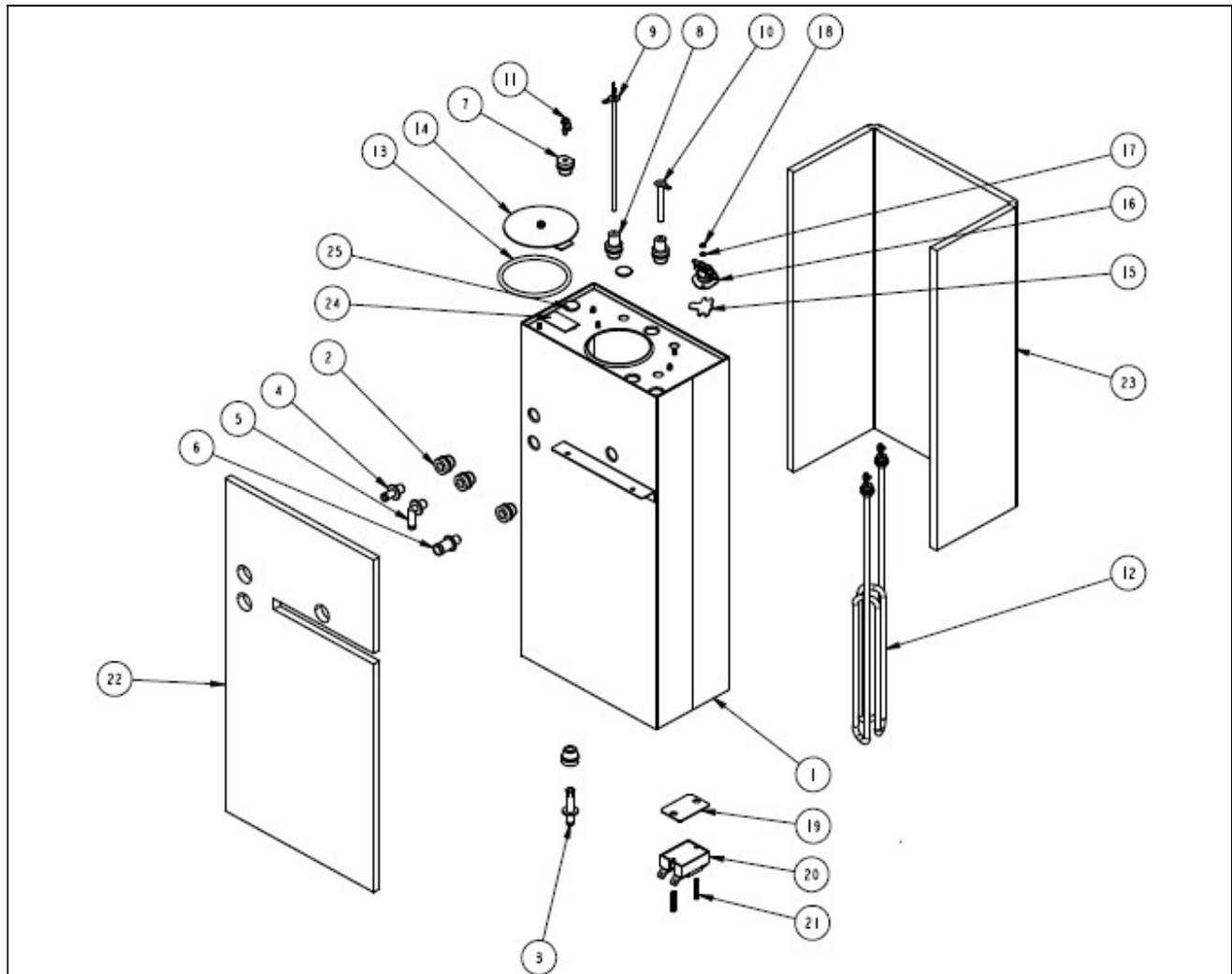

TANK ASSY CBS-2151 XTS Drawing #1104.00061.00			
Ref	#	Part Number	Name
1	1	1114.00087.00	WELDMENT, TANK, CBS-2151
2	4	1024.00050.00	GROMMET, SILICONE, 11,4mm ID
3	1	1023.00166.00	FITTING, COLD WATER INLET, GROMMET DESIGN
4	1	1023.00168.00	FITTING, HOT WATER, GROMMET DESIGN
5	1	1023.00183.00	FITTING, DILUTION, TBS-2121
6	1	1023.00203.00	FITTING, BREW, GROMMET DESIGN
7	1	1024.00062.00	GROMMET, SHORT, SILICONE, LEVEL AND TEMP PROBE
8	2	1024.00053.00	LEVEL AND TEMP PROBE GROMMET
9	1	1102.00161.00	PROBE ASSEMBLY, TEMP. AND LLC, HWD-2100
10	1	1112.00019.00	PROBE WELDMENT, WATER LEVEL 2.600" LG
11	1	1029.00023.00	FITTING, SINGLE BARBED ELBOW, 1/4", KYNAR
12	1-3	1107.00005.00	HEATER ASSEMBLY, IMMERSION 3000W/240VAC
12	1-3	1107.00010.00	HEATER ASSEMBLY, IMMERSION 4000W/240VAC
12	1-3	1107.00032.00	HEATER ASSEMBLY, IMMERSION 5000W/240VAC
12	1-3	1107.00037.00	HEATER ASSEMBLY, IMMERSION 2300W/240VAC
13	1	1024.00007.00	O-RING, DASH #344, TANK COVER
14	1	1102.00007.00	TANK COVER ASSEMBLY
15	2	1003.00005.00	BRACKET, ONE SHOT THERMOSTAT
16	2	1053.00003.00	THERMOSTAT, SINGLE SHOT, 240V/40A
17	4-12	1083.00009.00	WASHER, #6 SCREW, INTL TOOTH LOCKWASHER
18	4-12	1084.00010.00	NUT, HEX, #6-32, UNDERSIZED, ZINC PLATED
19	1-3	1003.00140.00	ALUMINUM BRACKET FOR SSR
20	1-3	1052.00033.00	RELAY, SOLID STATE, 50A/600VAC, W/BUILD IN VARISTOR
21	4-12	1081.00042.00	STANDOFF, 1/4" HEX
22	1	1022.00068.00	INSULATION, TANK FRONT, CBS-2151
23	1	1022.00069.00	INSULATION, TANK BACK, CBS-2151
24	1	1044.00004.00	LABEL, DANGER-HIGH VOLTAGE
25	2	1024.00054.00	GROMMET, SILICONE PLUG
	4	1065.00006.00	CONNECTOR, TAB, .250", FASTON

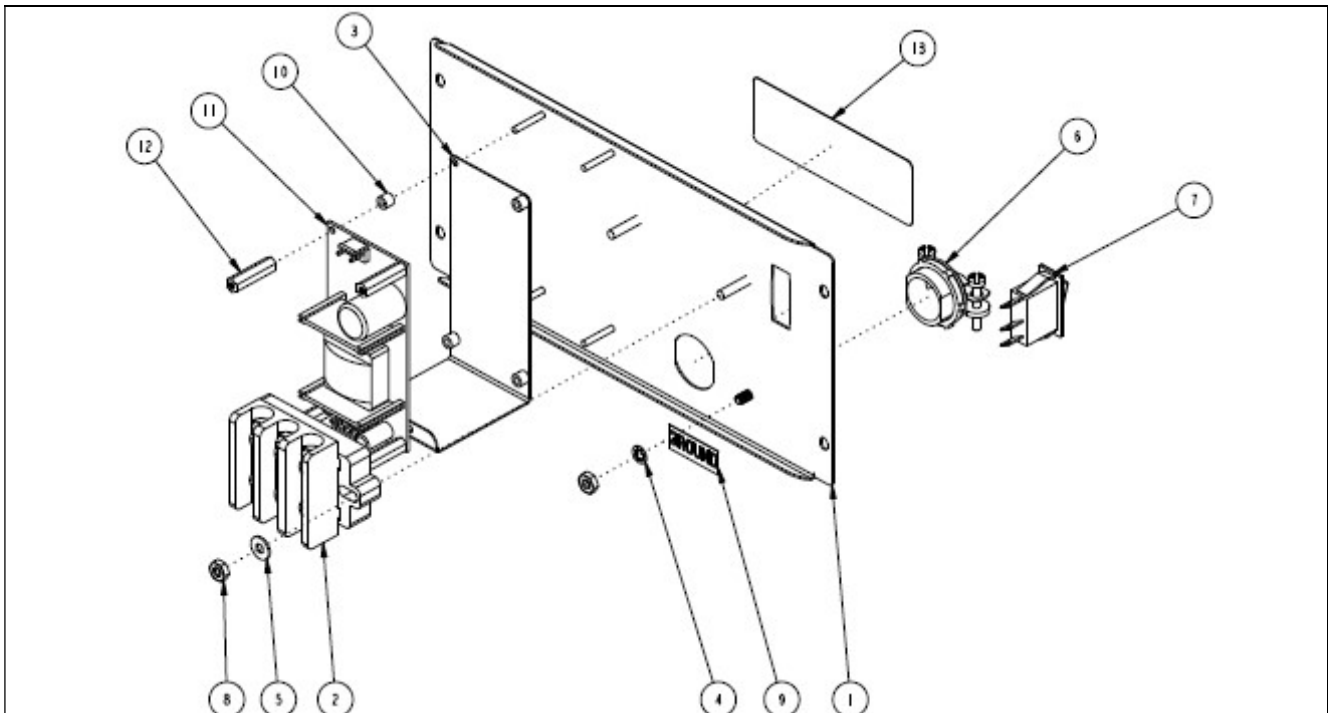

Ref	#	Part Number	Name
			BACK PANEL ASSEMBLY, CBS-2151XTS Drawing 1102.00231.00
1	1	1112.00281.00	WELDMENT, BACK PANEL, CBS-2151
2	1	1052.00002.00	TERMINAL BLOCK, 3 POLE, W/ MARKING STRIP
3	1	1003.00170.00	BRACKET, GUARD
4	1	1083.00011.00	WASHER, #8 SCREW SIZE, INTERNAL TOOTH LOCK
5	2	1083.00016.00	WASHER, #8 SCREW SIZE, FLAT
6	1	1086.00008.00	CONNECTOR, CABLE CLAMP, 3/4"
7	1	1058.00020.00	SWITCH, PWR ROCKER RED, ILLUM. 250VAC
8	3	1084.00006.00	NUT, 8-32 18-8 HEX MACHINE SCREW
9	1	1044.00003.00	LABEL GROUND
10	4	1081.00006.00	SPACER, 6MM OD x 3.2MM ID x 5MM LG, Z/P
11	1	1052.00001.00	POWER SUPPLY, 90-264VAC/24VDC, 1.8A
12	4	1029.00012.00	SPACER, .25" HEX X 1" LG, FEM #4-40 THREAD
13	1	1046.00030.00	LABEL WARNING, DISCONNECT FROM POWER SOURCE

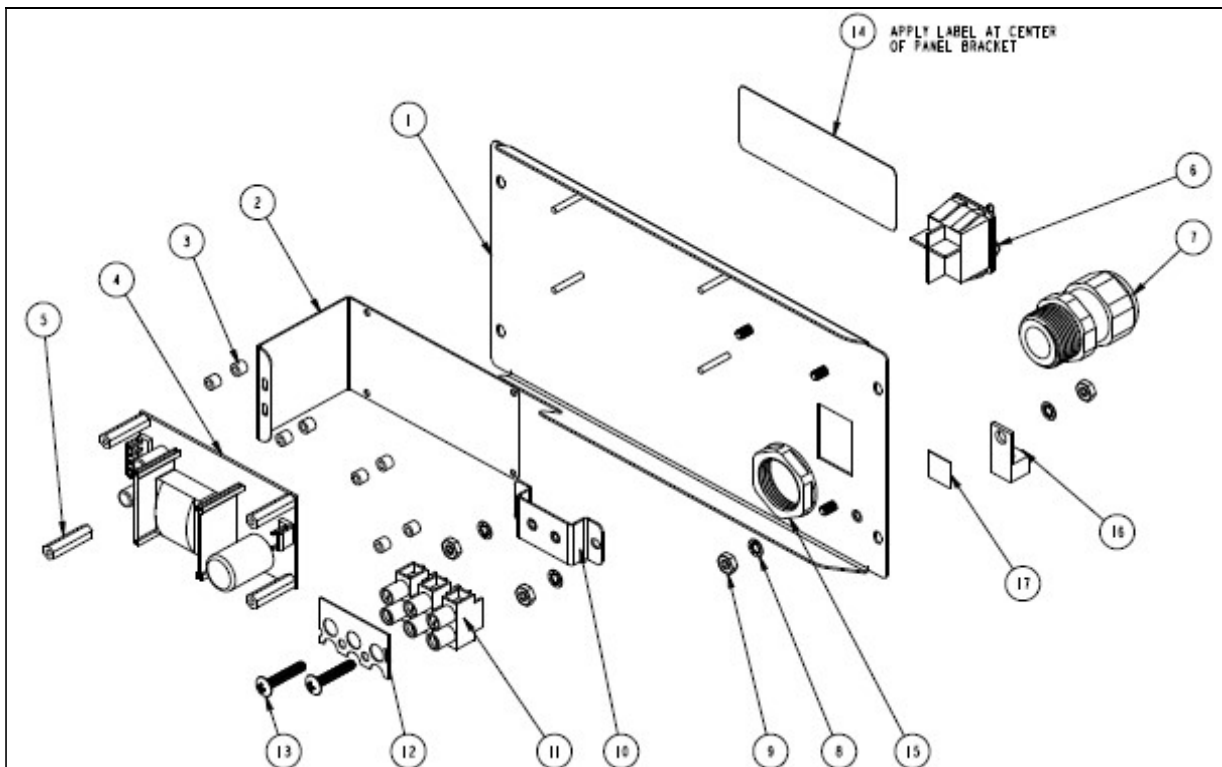

BACK PANEL ASSEMBLY, CE CBS-2151XTS Drawing 1102.00216.00

Ref	#	Part Number	Name
1	1	1112.00261.00	WELDMENT, BACK PANEL, CBS-2151, CE
2	1	1003.00170.00	BRACKET, GUARD
3	8	1081.00006.00	SPACER, 6MM OD x 3.2MM ID x 5MM LG, Z/P
4	1	1052.00001.00	POWER SUPPLY, 90-264VAC/24VDC, 1.8A
5	4	1029.00012.00	SPACER, .25" HEX X 1" LG, FEM #4-40 THREAD
6	1	1058.00024.00	SWITCH, POWER, DOUBLE POLE, 16A, 125/250 VAC
7	1	1086.00031.00	BUSHING, STRAIN RELIEF, BLACK, .354"-.630"
8	4	1083.00011.00	WASHER, #8 SCREW SIZE, INTERNAL TOOTH LOCK
9	4	1084.00006.00	NUT, 8-32 18-8 HEX MACHINE SCREW
10	1	1112.00246.00	WELDMENT BRACKET TERMINAL BLOCK, 3 POLE
11	1	1052.00022.00	EUROSTRIP HE6 TERM. BLK., 3 POLE, 40AMP, 10-20 TERM. BLK.
12	1	1052.00025.00	PLATE, MARKING #BS1016E
13	2	1082.00082.00	SCREW, PHILLIP HD., 8-32 THREAD
14	1	1046.00030.00	LABEL WARNING, DISCONNECT FROM POWER SOURCE
15	1	1086.00032.00	LOCKNUT, HEX BLACK, FOR SKINTOP RELIEF
16	1	1065.00009.00	GROUND LUG CONNECTOR, 14-2 AWG, ALUMINUM
17	1	1044.00013.00	LABEL EQUIPOTENTIALITY CE

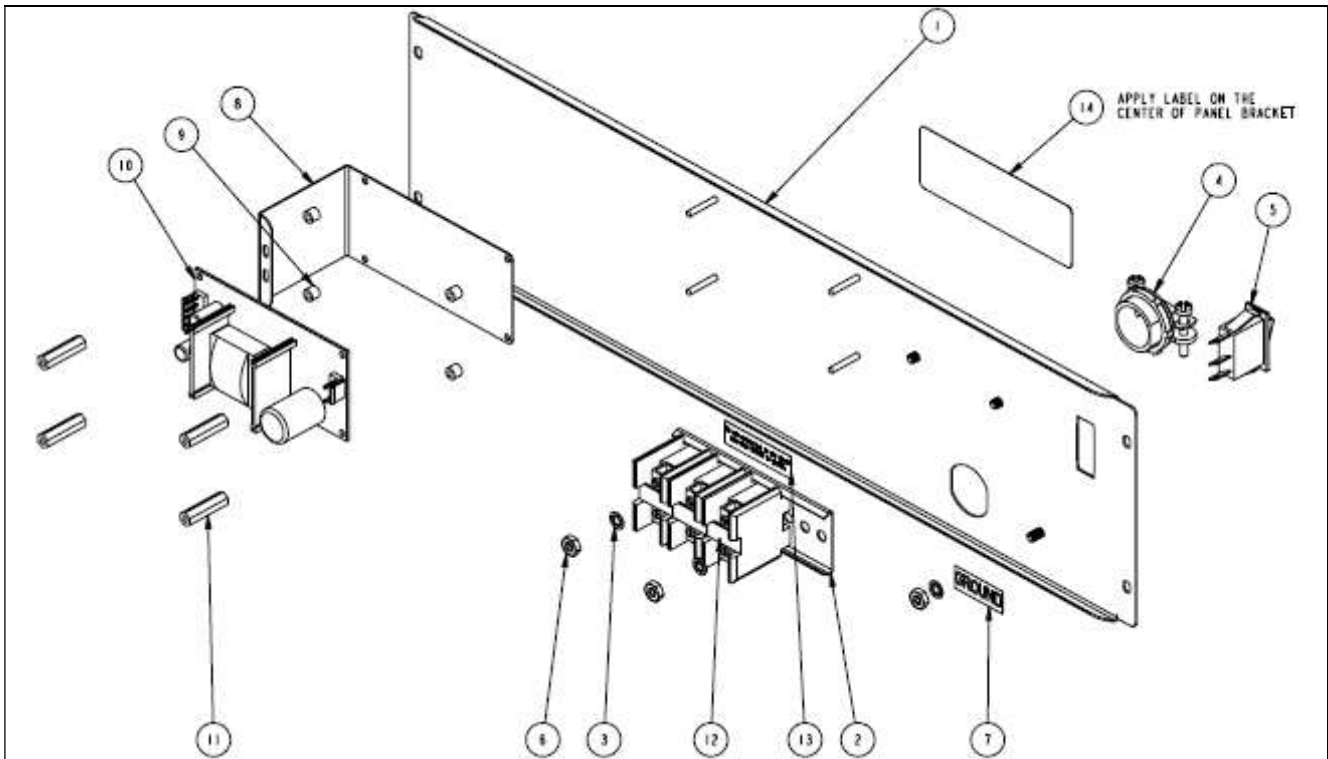

BACK PANEL ASSEMBLY, CBS-2152XTS Drawing 1102.00229.00			
Ref	#	Part Number	Name
1	1	1112.00280.00	WELDMENT BACK PANEL, CBS-2152
2	1	1052.00005.00	TERMINAL BLOCK TRACK
3	3	1083.00011.00	WASHER, #8 SCREW SIZE, INTERNAL TOOTH LOCK
4	1	1086.00008.00	CONNECTOR, CABLE CLAMP, 3/4"
5	1	1058.00020.00	SWITCH, PWR ROCKER RED, ILLUM. 250VAC
6	3	1084.00006.00	NUT, 8-32 18-8 HEX MACHINE SCREW
7	1	1044.00003.00	LABEL GROUND
8	1	1003.00170.00	BRACKET, GUARD
9	4	1081.00006.00	SPACER, 6MM OD x 3.2MM ID x 5MM LG, Z/P
10	1	1052.00001.00	POWER SUPPLY, 90-264VAC/24VDC, 1.8A
11	4	1029.00012.00	SPACER, .25" HEX X 1" LG, FEM #4-40 THREAD
12	3	1052.00004.00	TERMINAL BLOCK
13	1	1044.00005.00	LABEL, CONNECTION WARNING FOR 3 PH
14	1	1046.00030.00	LABEL WARNING, DISCONNECT FROM POWER SOURCE

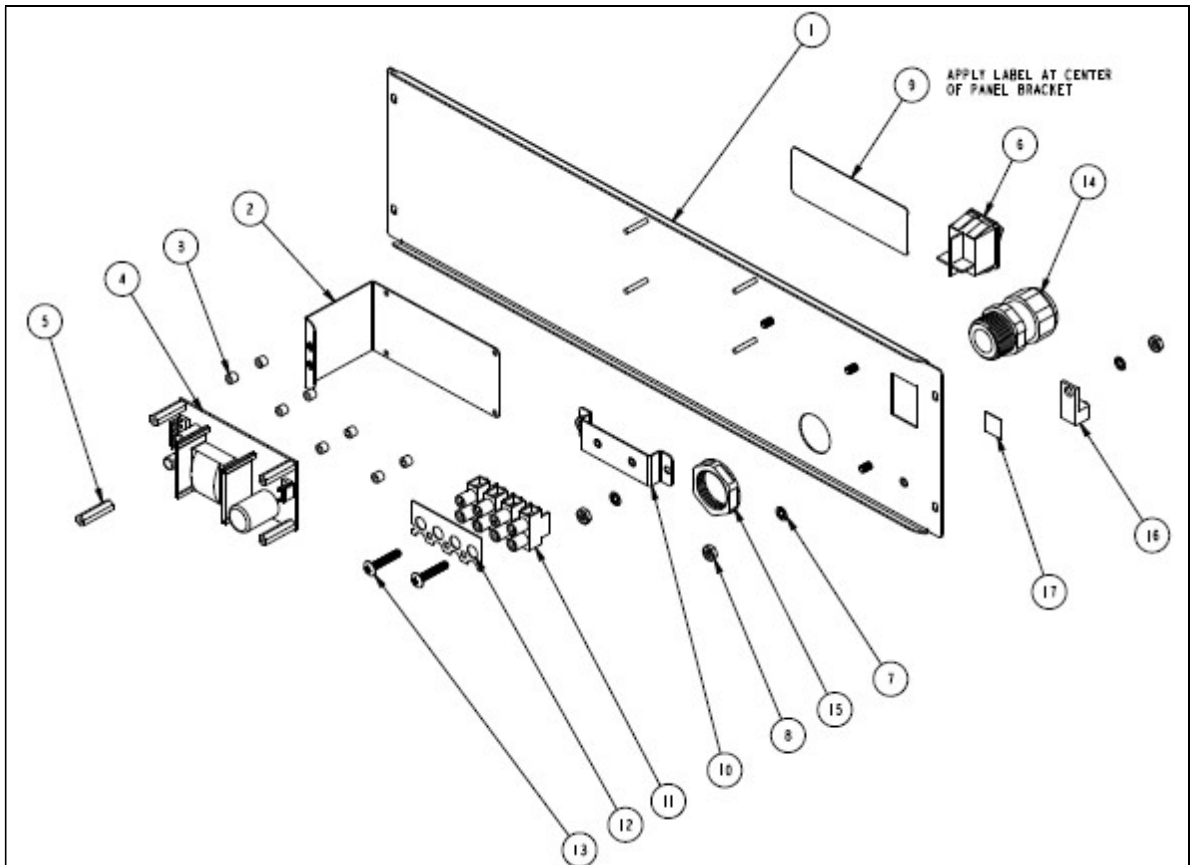

BACK PANEL ASSEMBLY, CBS-2152XTS Drawing 1102.00229.00			
1	1	1112.00267.00	WELDMENT, BACK COVER, CBS-2152, EU
2	1	1003.00170.00	BRACKET, GUARD
3	8	1081.00006.00	SPACER, 6MM OD x 3.2MM ID x 5MM LG, Z/P
4	1	1052.00001.00	POWER SUPPLY, 90-264VAC/24VDC, 1.8A
5	4	1029.00012.00	SPACER, .25" HEX X 1" LG, FEM #4-40 THREAD
6	1	1058.00024.00	SWITCH, POWER, DOUBLE POLE, 16A, 125/250 VAC
7	4	1083.00011.00	WASHER, #8 SCREW SIZE, INTERNAL TOOTH LOCK
8	4	1084.00006.00	NUT, 8-32 18-8 HEX MACHINE SCREW
9	1	1046.00030.00	LABEL WARNING, DISCONNECT FROM POWER SOURCE
10	1	1112.00268.00	WELDMENT, BRACKET TERMINAL BLOCK, 4 POLE
11	1	1052.00023.00	EUROSTRIP HE10 TERMINAL BLOCK, 4 POLE, 50AMP, 18-8
12	1	1052.00025.00	PLATE, MARKING #BS1016E
13	2	1082.00082.00	SCREW, PHILLIP HD., 8-32 THREAD
14	1	1086.00031.00	BUSHING, STRAIN RELIEF, BLACK, .354"-.630"
15	1	1086.00032.00	LOCKNUT, HEX BLACK, FOR SKINTOP RELIEF
16	1	1065.00009.00	GROUND LUG CONNECTOR, 14-2 AWG, ALUMINUM
17	1	1044.00013.00	LABEL EQUIPOTENTIALITY CE

FETCO CBS-2151 Water handling system

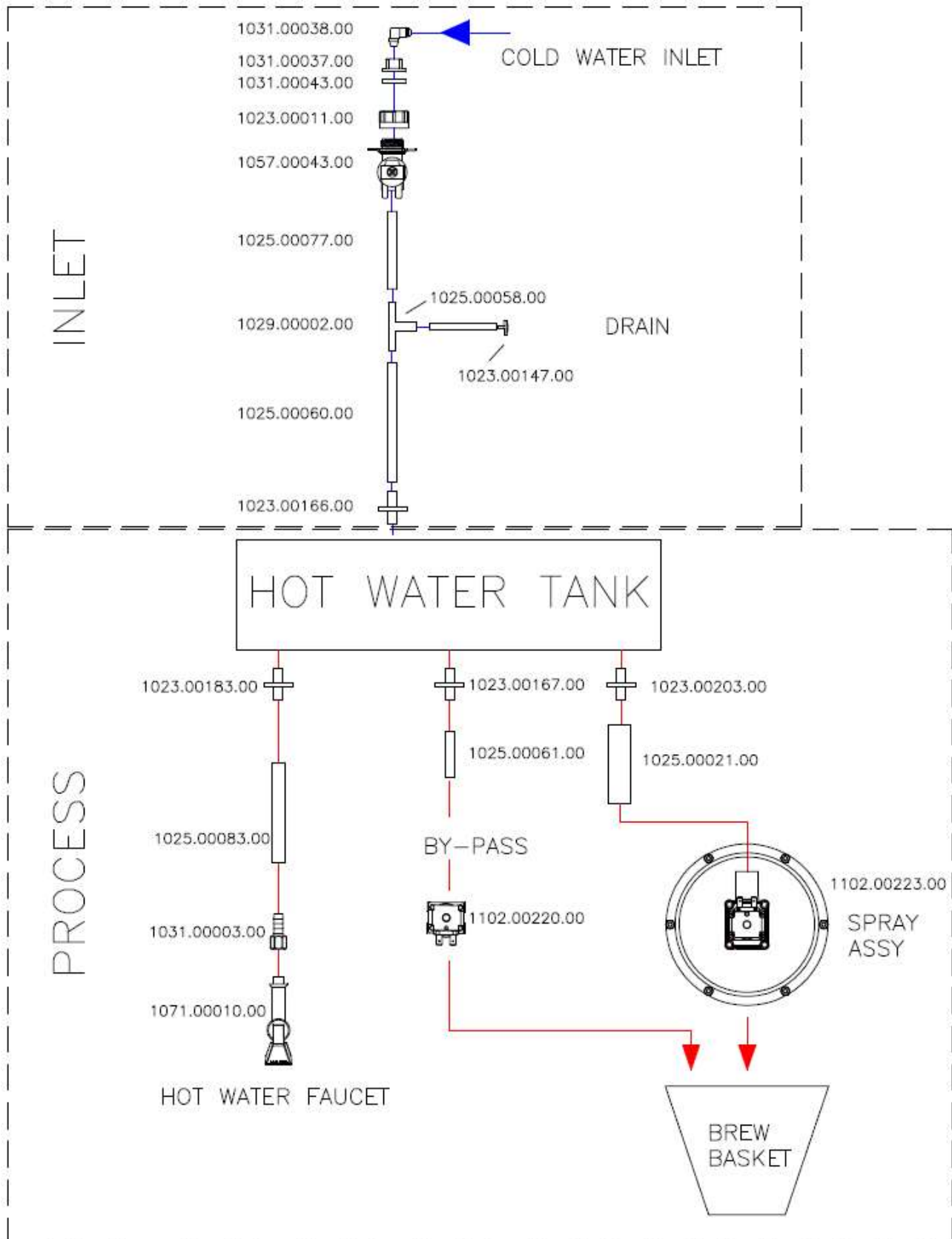

CBS-2152XTS Water Handling System

